

## R420

## 16 digital input module



**Summary**            The R420 digital input module is a microprocessor-controlled, communicative 16 binary inputs module. The module uses a RS485 bus with Modbus RTU, and can be easily integrated in a variety of supervision and control systems.

**Application**            •    HVAC and industrial control systems – binary signal acquisition

**Function**                The inputs are designed for small voltage up to 50 V DC, 30 V AC. All inputs have a common ground – COM. The inputs are optically separated from the rest of the circuitry.

The module communicates by means of a optically insulated RS485 data bus. The communication protocol ensures smooth and easy integration in a number of control and data acquisition systems. Removable connectors are used for incoming and outgoing data line so that mounting is fast and easy. The module is installed on a DIN rail.

The communication circuits are protected against overvoltage. If the module is terminating the communication bus, i.e. it is the first or last in line, a terminating 120 Ω resistor shall be switched on by short-circuiting of the BUS END DIP switches (1, 2). Three LEDs located inside of the housing enable fast diagnostics – power up and communication. 16 LEDs at the inputs indicate the status of each of the inputs separately.

All settings are stored in a EEPROM. The module is equipped by a watchdog.

See *domat - Technical application notes* for connection examples.

<b>Technical data</b>	Power	24 V AC/DC ± 20 %
	Consumption	1 W
	Communication	Modbus RTU RS485, 1200...115200 bit/s
	Galvanic isolation	1 kV
	Max. bus length	1200 m
	Max. amount of modules on the bus	256
	Number of digital inputs	16 × digital inputs (logical zero is <5 VAC/DC, logical one is >18 VAC/DC, 7 mA)
	Software	ModComTool 4.2.3.9 or higher for parameter setting, Merbon IDE, SoftPLC IDE – predefined Modbus devices
	Housing	polycarbonate box (certification UL94V0) Elbox 6
	Terminals	screw terminals M3 (bus, power), M2 (digital inputs)
	Dimensions	105.6 × 98.7 × 61.5 mm
	Protection degree	IP20 (EN 60529)
	Recommended wire	0.14...1.5 mm <sup>2</sup>
	Ambient temperature	external conditions: -5...45 °C; 5...95 % relative humidity; non-condensing gases and chemically non-aggressive conditions (according to EN 60721-3-3 climatic class 3K5) storage: -5...45 °C; 5...95 % relative humidity; non-condensing gases and chemically non-aggressive conditions (according to EN 60721-3-1 climatic class 1K3)
	Standards conformity	EMC EN 61000-6-2 ed.3:2005, EN 61000-6-4 ed.2:2006 + A1:2010 (industrial environment) electrical safety EN 60950-1 ed.2:2006 + A11:2009 + A12:2011 + A1:2010 + A2:2014 + Opr.1:2012 + Z1:2016 hazardous substances reduction EN 50581:2012

## Terminals

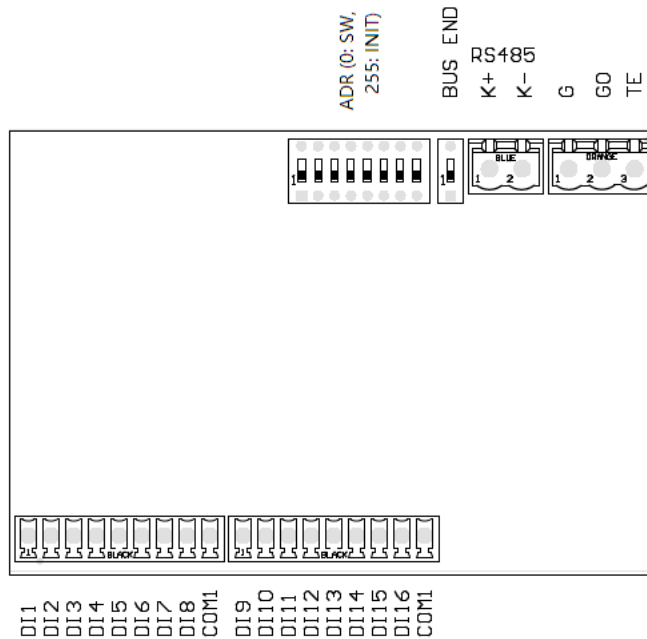

### Terminals and connectors

<b>RS485 K+</b>	port COM - serial link RS485, terminals K+
<b>RS485 K-</b>	port COM - serial link RS485, terminals K-
<b>G</b>	G power supply
<b>G0</b>	G0 power supply
<b>TE</b>	optional connection for shielding, technical ground
<b>COM1</b>	common terminals for DI1...DI16
<b>DI1 ... DI16</b>	inputs 1...16

### LED indication

<b>RUN</b>	orange LED – system cycle (OK: LED flashes periodically 1 s ON, 1 s OFF; ERROR: LED flashes in other pattern, LED is still ON or OFF)
<b>TxD</b>	red LED – RS485 transmitting data at COM (flashing: transmitting data; OFF: no data traffic)
<b>PWR</b>	green LED – power supply (ON: power OK; OFF: no power applied, weak or damaged power supply, ...)

### DIP switches

<b>ADR</b>	AUTO – if all switches are OFF, the address is used according to Modbus register 4 LSB USER – address is set by DIP switches configuration INIT - if are all switches ON at power-up, configuration parameters are set to defaults <b>DIP 8 = bit 0; switches increase their bit weight from right to left, see below</b>
<b>BUS END</b>	Switch for bus RS485 termination (located at the RS485 connector); ON = bus end; the first and last devices on bus should have bus end ON

## Connection

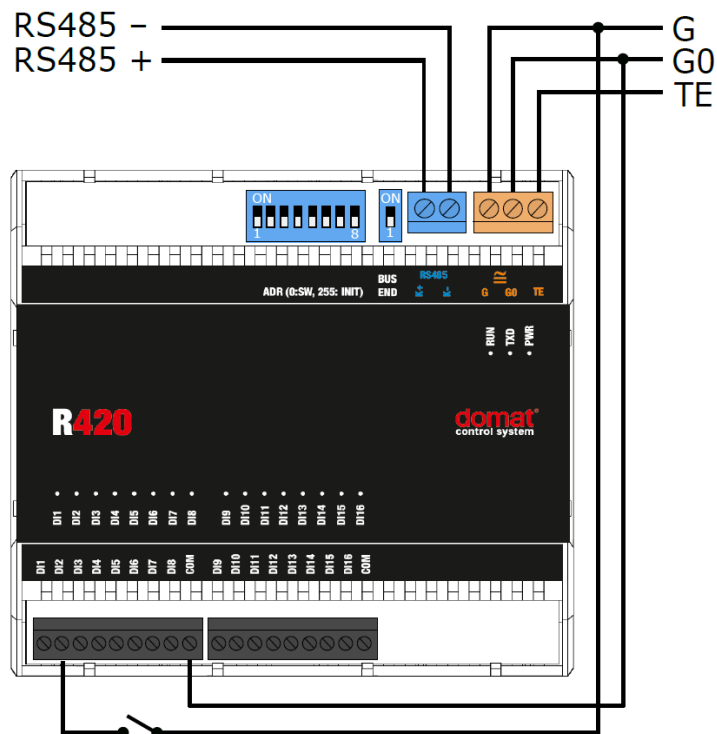

## Dimensions

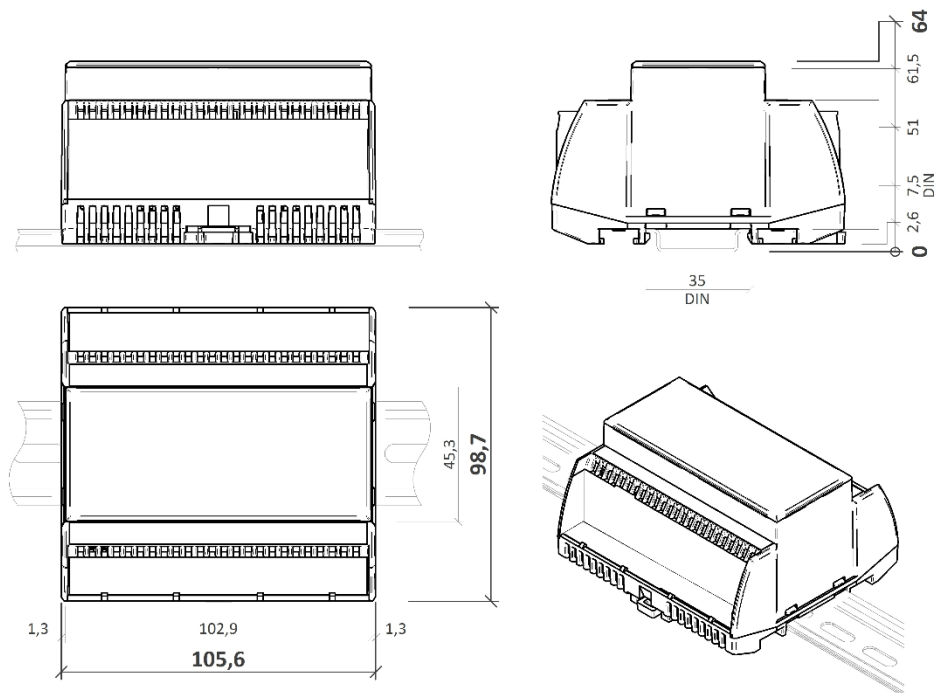

Dimensions are in *mm*.

## Installation

The R420 module is fixed by snapping on standard DIN rail.

When removing the module from the DIN rail proceed as follows: Place a screwdriver in the plastic slot which is in the middle of bottom part of the module (1). Then push the screwdriver upwards (2). After that, the module can be removed by tilting it upwards (3).

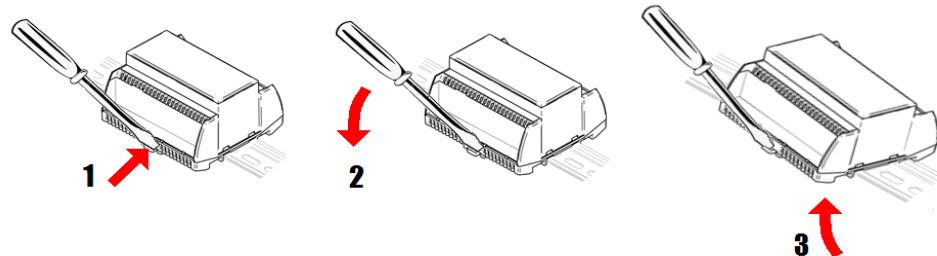

## Addressing

The Modbus address can be set as follows:

- **hardwarewise:** using DIP switches. The switches increase their bit weight from right to left, see image with example where address of 21 is set by activation of switches 4, 6, and 8 with bit weight of 16, 4, and 1 respectively. Valid settable range is 1 to 254. Address 0 (all switches OFF) means that the address is set as entered in the Modbus table. Address 255 (all switches ON) brings the module to INIT mode, where Modbus address is 1 and communication parameters are set to N, 8, 1, see image below. All changes apply after the module is switched off and on again.

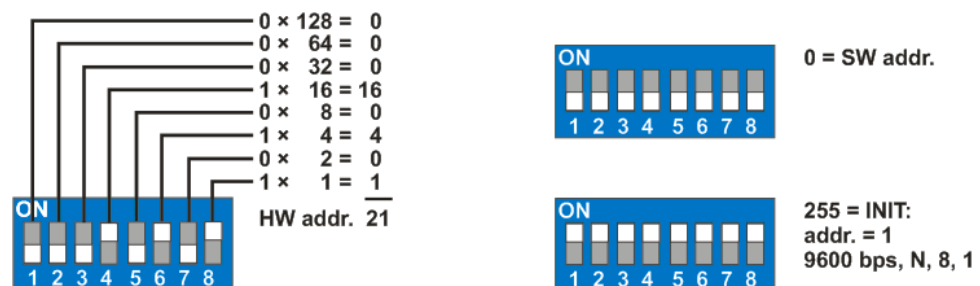

- **softwarewise** using the ModComTool software, available for free at [www.domat-int.com/en/](http://www.domat-int.com/en/). The default address (factory setting) is 1, default communication parameters are 9600, 8, N, 1. Parity and stopbits can be set in Modbus register 1005 LSB. **The software address is only active if the hardware addressing switch is set to 0.** All changes apply after the module is switched off and on again.

## Safety note

The device is designed for monitoring and control of heating, ventilation, and air conditioning systems. It must not be used for protection of persons against health risks or death, as a safety element, or in applications where its failure could lead to physical or property damage or environmental damage. All risks related to device operation must be considered together with design, installation, and operation of the entire control system which the device is part of.

**Changes in  
versions**

06/2018 – First datasheet version.

08/2021 – Stylistic adjustments, change of logo.