

# T-Px Temperature Sensor Range

## T-Px Temperature Sensor Range



### Description

A range of highly accurate temperature sensors built around the PT1000 Platinum RTD sensing element.

The range comprises a number of plant sensors offering measurement through contact (T-PC), external/outside air (T-PO), insertion/immersion (T-PI) and MPHWH/HPHW immersion (T-PI-160) applications. These sensors feature an IP67 junction box which houses the sensor electronics and connections.

A wall-mountable room space sensor (T-PS) is also available.

### Features

- PT1000 accuracy
- 4 to 20 mA output
- 20 to 28 Vdc supply range
- Simple 2-wire connection
- Variants for contact, immersion, ducted or free air measurement
- IP67 (NEMA 6) rating for plant sensors

### Physical

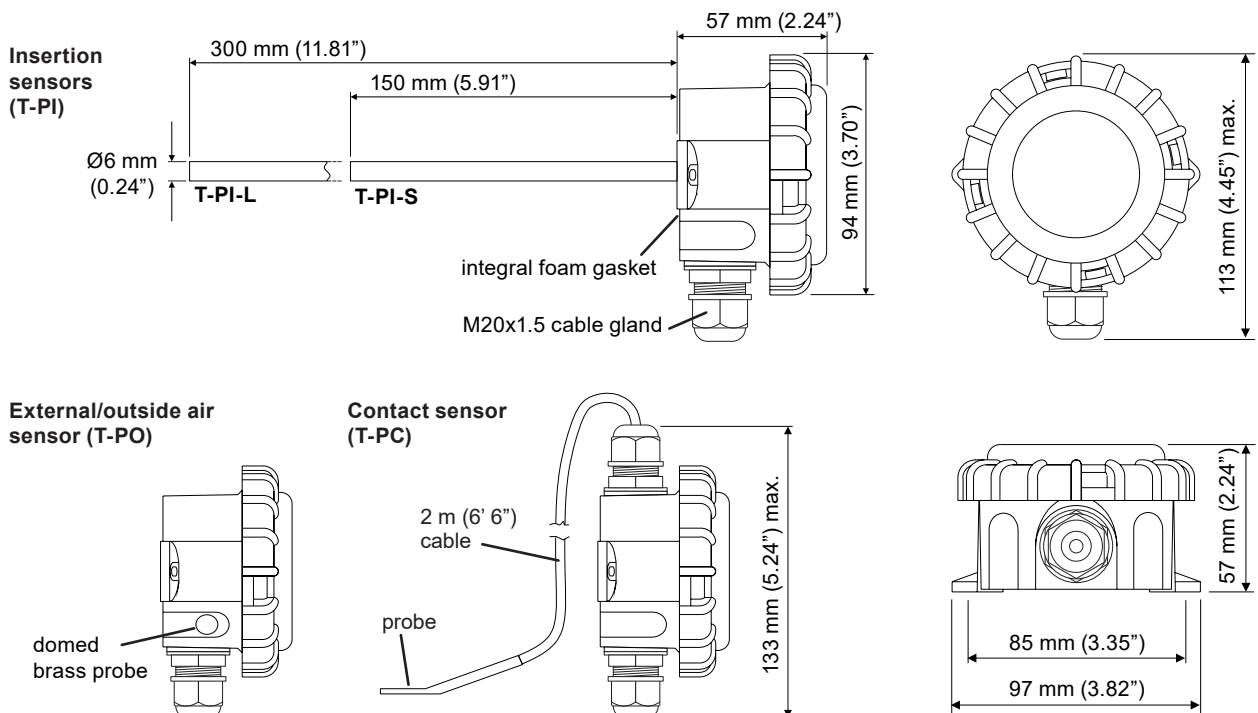

**Physical** (continued)

**Immersion sensor  
(T-PI-160)**

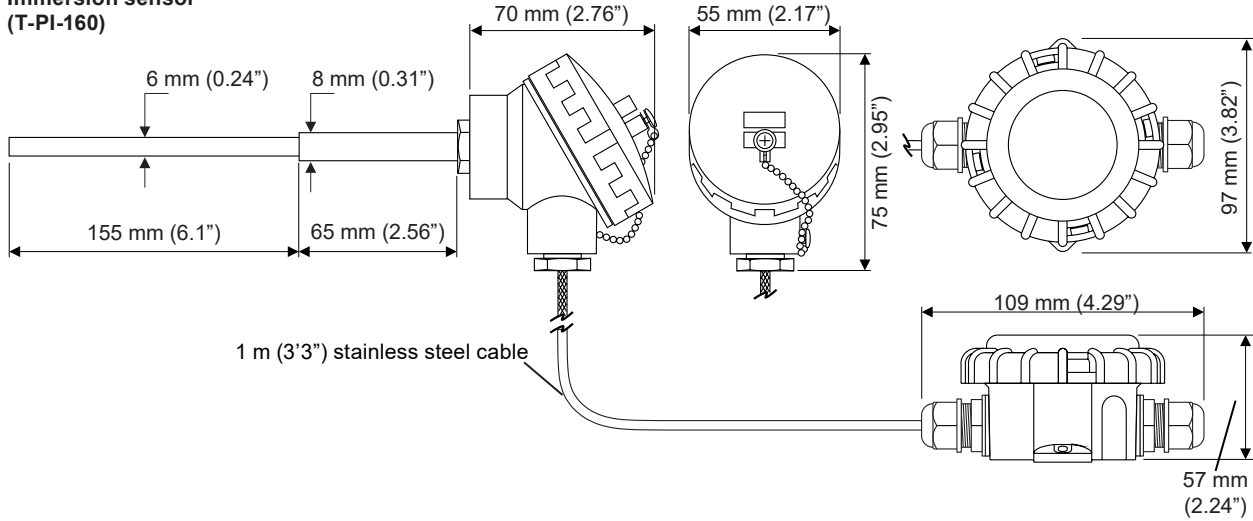

Pockets for using the T-PI as immersion sensor: Brass (WB150); Stainless Steel (WS150)

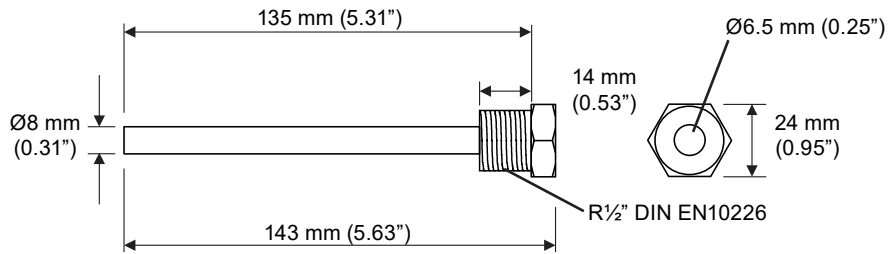

Mounting Flange (ACC/DF) for using the T-PI as duct sensor

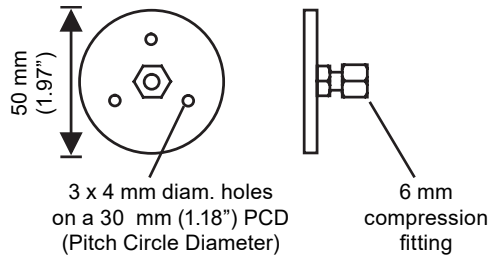

**Room space sensor  
(T-PS)**

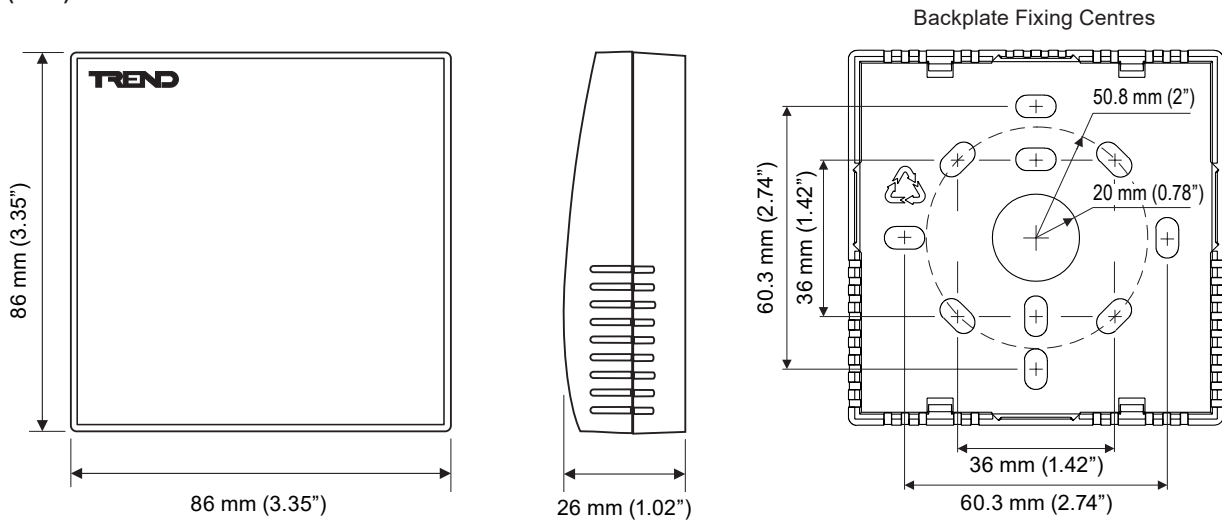

## INSTALLATION

### MECHANICAL

#### T-PC Contact Sensor

The T-PC features a sensor probe on a flying lead. The probe is designed to be secured to an item of equipment, typically a water pipe with a minimum diameter of 12 mm (0.5”).

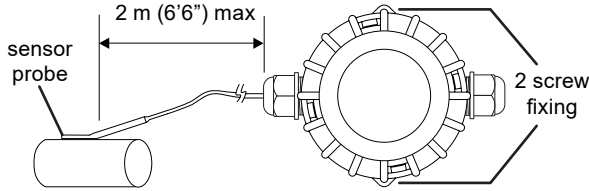

A jubilee clip is supplied with the sensor allowing the probe to be clamped to pipe diameters up to 203 mm (8”). Alternatively, the probe can be secured using cable ties (not supplied). Where possible a thermally conductive paste should be used to ensure a good thermal contact and the sensor probe must be fitted beneath any insulation material.

The junction box can be mounted on a convenient flat surface using two No.6 screws (not supplied) up to 2 m (6’ 6”) away from the sensor probe. The box must not be mounted where it may encounter direct contact with steam.

Full installation instructions are included with the sensor – see T-PC Contact Temperature Sensor Installation Instructions (TG201418).

#### T-PO External/Outside Air Sensor

The T-PO sensor is designed to be mounted on an exterior wall located away from direct sunlight, typically north-facing in the northern hemisphere (or south-facing in the southern hemisphere). It must also be positioned away from any heat sources which may come from the building, e.g. heating flues, vents, open windows, etc.

The sensor is secured to the wall using two No.6 screws and suitable wall plugs (not supplied).

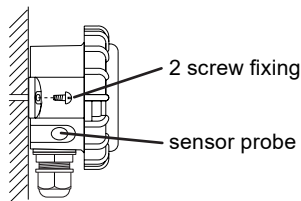

Full installation instructions are included with the sensor – see T-PO External Air Temperature Sensor Installation Instructions (TG201419).

#### T-PI Insertion Sensor

The T-PI is suitable as either a duct or immersion sensor and is available with the following probe lengths:

- T-PI-L 300 mm (11.81”)
- T-PI-S 150 mm (5.91”)

##### Use as a Duct Sensor

The sensor can either be mounted directly onto the duct or by using the optional ACC/DF mounting flange. The flange enables the depth of the probe to be adjusted. For either mounting option a 7 mm (0.28”) hole is required for the probe.

**Direct mounting** requires the junction box to be secured using two No.6 screws (not supplied). The supplied foam gasket is used to provide a good seal around the probe entry hole:

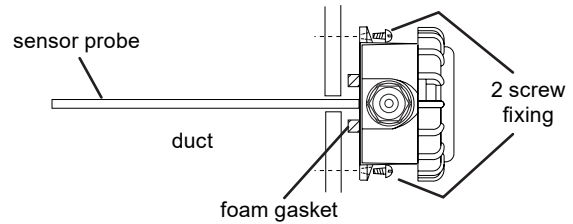

**Flange mounting** requires the ACC/DF flange to be fitted using three No.6 screws. The probe is then secured at the required depth using a compression fitting:

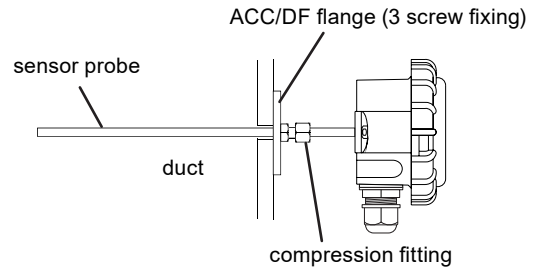

##### Use as an Immersion Sensor

In immersion applications the sensor probe must be used in conjunction with a suitable pocket.

The T-PI-S is compatible with the WB150 (brass) or WS150 (stainless steel) pockets. These are designed for use with a R $\frac{1}{2}$ ” DIN EN10226 threaded boss and have integral spring compression to retain the sensor probe.

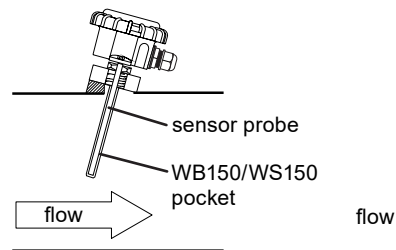

*Note: The WS150 pocket is not suitable for use in a chlorine rich environment.*

The pocket should be positioned in an accessible location where it will lie in the liquid to be measured. Ensure there is no stratification in the liquid flow being measured (e.g. by positioning downstream of mixing valves or junctions). If used for chilled water ensure that the pocket is sealed around the probe, or fill the pocket with thermally conducting oil, to avoid the build up of condensation in the bottom of the pocket.

Full installation instructions are included with the sensor – see T-PI Insertion Thermistor Temperature Sensor Installation Instructions (TG201420).

**T-PI-160 Immersion Sensor**

The T-PI-160 is an immersion sensor suitable for use in medium and high pressure hot water systems. The sensor probe is connected to the junction box via a stainless steel covered cable.

The sensor probe must be used in conjunction with a suitable pocket, e.g. the WS150 (stainless steel) pocket. This is designed for use with a R½" DIN EN10226 threaded boss and has an integral spring compression to retain the sensor probe.

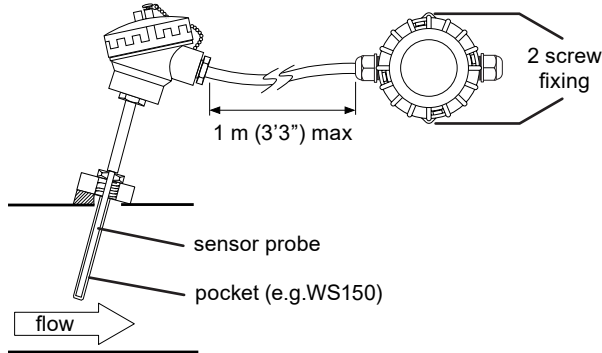

*Note: The WS150 pocket is not suitable for use in a chlorine rich environment. The WB150 is not suitable for use with T-PI-160.*

The pocket should be positioned in an accessible location where it will lie in the liquid to be measured. Ensure there is no stratification in the liquid flow being measured (e.g. by positioning downstream of mixing valves or junctions). If used for chilled water ensure that the pocket is sealed around the probe, or fill the pocket with thermally conducting oil, to avoid the build up of condensation in the bottom of the pocket.

The junction box can be mounted on a convenient flat surface using two No.6 screws (not supplied) up to 1 m (3' 3") away from the sensor probe. The box must not be mounted where it may encounter direct contact with steam.

Full installation instructions are included with the sensor – see T-PI-160 Immersion Sensor Installation Instructions (TG201421).

**T-PS Space Temperature Sensor**

The T-PS sensor is housed in a two-part plastic enclosure. The backplate has a selection of fixing holes allowing the sensor to be secured to most types of wall box, or mounted directly to a wall (fixings not supplied).

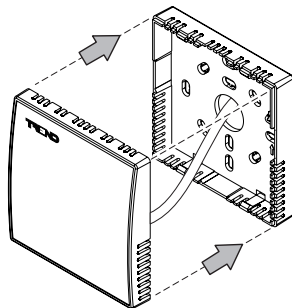

Full installation instructions are included with the sensor – see T-PS Space Temperature Sensor Installation Instructions (TG201422).

**ELECTRICAL**

The T-PC, T-PI, T-PI-160 and T-PO sensors all have a tough ABS junction box which houses the sensor electronics and connections. The quick-release lid gives access to a PCB featuring a 2-part 2-pole screw terminal block.

Cable entry is through an M20x1.5 cable entry gland. Alternatively the gland can be removed and the junction box connected directly to 20 mm rigid or flexible conduit using a suitable adapter (not supplied).

The T-PS has a PCB with fixed screw terminals. Cable entry is either from the rear, via the hole in the centre of the back plate, or from the sides, top or bottom edge via various knock-outs.

All sensors are suitable for use with IQ Controllers or I/O modules and can be wired to universal inputs (configured for loop powered current operation).

Wiring example

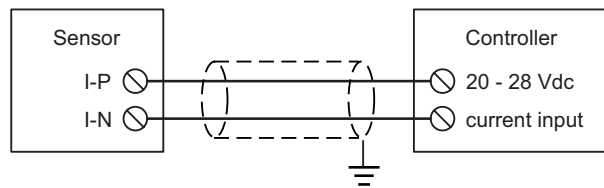

*Note: Where screened cable is used the screen must be earthed/grounded at the controller end only.*

**Sensor Scaling**

Appropriate sensor type scaling must be applied (see the relevant sensor Installation Instructions for details).

## FIELD MAINTENANCE

The T-Px Temperature Sensors requires virtually no routine maintenance. The unit should be cleaned with a cloth moistened with water in order to avoid buildup of dust or other contaminants. **Disconnect power before carrying out any cleaning.**

## DISPOSAL

COSHH (Control of Substances Hazardous to Health - UK Government Regulations 2002) ASSESSMENT FOR DISPOSAL OF T-Px Temperature Sensors.

### RECYCLING

All plastic and metal parts are recyclable. The printed circuit board may be sent to any PCB recovery contractor to recover some of the components for any metals such as gold and silver.



**WEEE Directive:**

At the end of their useful life the packaging, and product, and battery (if fitted) should be disposed of by a suitable recycling centre.

Do not dispose of with normal household waste.  
Do not burn.

## COMPATIBILITY

**Controllers:** All IQ controllers with current or universal inputs.

## ORDER CODES

<b>T-PC</b>	Contact temperature sensor with jubilee clip.
<b>T-PI-S</b>	Insertion temperature sensor (for duct or immersion use) with 150 mm probe.
<b>T-PI-L</b>	Insertion temperature sensor (for duct use) with 300 mm probe.
<b>T-PI-160</b>	Immersion temperature sensor (-10 to +160°C) with 155 mm probe.
<b>T-PO</b>	External/outside air temperature sensor.
<b>T-PS</b>	Space temperature sensor.

### Accessories

<b>ACC/DF</b>	Adjustable depth flange for duct use.
<b>WS150</b>	6 mm stainless steel pocket (immersion use).
<b>WB150</b>	6 mm brass pocket (immersion use).





## SPECIFICATION

### T-PC, T-PI-L, T-PI-S, T-PI-160, T-PO

#### Electrical

Sensing Element	Platinum RTD, 1000 $\Omega$ @ 0°C (32°F) (IEC 60751:2008, Class A)
Measurement Range	
T-PC	-10°C to +110°C (+14°F to +230°F)
T-PI-S, T-PI-L	-10°C to +110°C (+14°F to +230°F)
T-PI-160	-10°C to +160°C (+14°F to +320°F)
T-PO	-40°C to +50°C (-40°F to +122°F)
Accuracy	
Sensing element	dt= $\pm(0.15+0.002 \cdot  t )$ °C
Transmitter	dt= $\pm(0.15+0.016 \cdot  t-20 )$ °C
Output Signal	4 to 20 mA, 2 wire
Supply Voltage	20 to 28 Vdc (24 Vdc nominal)

#### Mechanical

Dimensions	Refer to diagrams on pages 1 & 2
Weight	
T-PC	0.214 kg
T-PI-L	0.165 kg
T-PI-S	0.142 kg
T-PI-160	0.392 kg
T-PO	0.135 kg
Cable Entry	M20 conduit with M20x1.5 cable gland fitted (suitable for cable $\varnothing$ 4 to 7mm).
Connections	2 part screw terminals
Cable Size	0.5 to 2.5 mm <sup>2</sup> (20 to 14 AWG)
Material	
Junction box	Impact resistant ABS (grey)
T-PC probe	Brass nickel plated
T-PI-L or S probe	316 stainless steel
T-PI-160 probe	316 stainless steel
T-PI-160 head	Cast aluminium
T-PI-160 cable	Braided stainless steel
T-PO probe	Brass

#### Pockets

Probe Retention	Spring compression
Operating Pressure	
WS150	25 bar maximum
WB150	13 bar maximum
Material	
WS150	Stainless steel
WB150	Brass

#### Environmental

Ambient Limits	
Operating	
Junction box	-40°C to +50°C (-40°F to +122°F)
T-PC probe	-40°C to +160°C (-40°F to +320°F)
T-PI-x probe	-40°C to +110°C (-40°F to +230°F)
T-PI-160 probe	-10°C to +160°C (+14°F to +320°F)
T-PO	-40°C to +50°C (-40°F to +122°F)
Humidity	
Junction box	0 to 90 % RH non condensing
Protection	IP67, NEMA6

### T-PS

#### Electrical

Sensing Element	Platinum RTD, 1000 $\Omega$ @ 0°C (32°F) (IEC 60751:2008, Class A)
Measurement Range	-10°C to +40 C (+14°F to +104°F)
Accuracy	
at -10°C	$\pm 0.55^\circ\text{C}$
at +20°C	$\pm 0.3^\circ\text{C}$
at +40°C	$\pm 0.45^\circ\text{C}$
Output Signal	4 to 20 mA, 2 wire
Supply Voltage	20 to 28 Vdc (24 Vdc nominal)

#### Mechanical

Dimensions	Refer to diagrams on page 2
Weight	0.065 kg
Cable Entry	Rear (20 mm diameter hole), or knock-outs at top, bottom and sides.
Connections	Screw terminals
Cable Size	0.5 to 2.5 mm <sup>2</sup> (20 to 14 AWG)
Material (enclosure)	Flame retardant (V0) ABS (white)

#### Environmental

Ambient Limits	
Operating	-10°C to +50°C (+14°F to +122°F)
Humidity	0 to 90 % RH non condensing
Protection	IP20

Please send any comments about this or any other Trend technical publication to [techpubs@trendcontrols.com](mailto:techpubs@trendcontrols.com)



© 2022 Honeywell Products and Solutions SARL, Connected Building Division. All rights reserved. Manufactured for and on behalf of the Connected Building Division of Honeywell Products and Solutions SARL, Z.A. La Pièce, 16, 1180 Rolle, Switzerland by its Authorized Representative, Trend Control Systems Limited.

Trend Control Systems Limited reserves the right to revise this publication from time to time and make changes to the content hereof without obligation to notify any person of such revisions or changes.

#### Trend Control Systems Limited

St. Mark's Court, North Street, Horsham, West Sussex, RH12 1BW, UK. Tel: +44 (0)1403 211888, [www.trendcontrols.com](http://www.trendcontrols.com)