

User Guide

Modbus Gateways



Disclaimer of liability

The information contained in these instructions corresponds to the technical status at the time of printing of it and is passed on with the best of our knowledge. Softing does not warrant that this document is error free. The information in these instructions is in no event a basis for warranty claims or contractual agreements concerning the described products, and may especially not be deemed as warranty concerning the quality and durability pursuant to Sec. 443 German Civil Code. We reserve the right to make any alterations or improvements to these instructions without prior notice. The actual design of products may deviate from the information contained in the instructions if technical alterations and product improvements so require.

Trademarks

FOUNDATION™ and HART® are marks of the FieldComm Group of Austin, Texas, USA.
Modbus® is a registered trademark of Schneider Electric, licensed to the Modbus Organization, Inc.



OpenSource

To comply with international software licensing terms, we offer the source files of open source software used in our products. For details see <http://opensource.softing.com/>

If you are interested in our source modifications and sources used, please contact: info@softing.com

Softing Industrial Automation GmbH

Richard-Reitzner-Allee 6
85540 Haar / Germany
<http://industrial.softing.com>

 + 49 89 4 56 56-340
 + 49 89 4 56 56-488
 info.idn@softing.com
support.automation@softing.com



Scan the QR code to find the latest documentation on the product web page under Downloads.

Table of Contents

Chapter 1	About this guide.....	7
1.1	Read me first.....	7
1.2	Target audience.....	7
1.3	Typographic conventions.....	7
1.4	Document history.....	8
1.5	Related documentation and videos.....	8
1.6	Document feedback.....	8
Chapter 2	About the gateways.....	9
2.1	Intended use.....	9
2.2	Specifications.....	9
2.3	Supported features.....	10
2.4	System requirements.....	10
2.5	Safety precautions.....	10
Chapter 3	Installation.....	11
3.1	Hardware installation.....	11
3.1.1	Mounting and dismounting	11
3.1.2	Connection diagrams mbGate PA	12
3.1.3	Connection diagram mbGate PB	13
3.1.4	Connection diagram mbGate DP	13
3.1.5	Connecting the power supply	14
3.1.6	Installation positions	14
3.1.7	Connecting to the network	16
3.1.8	Powering up the device	17
3.2	Software installation.....	18
Chapter 4	Configuration.....	19
4.1	Prerequisites.....	19
4.2	Changing the IP address of a gateway.....	19
4.3	Setting the IP address of your PC.....	21
4.4	Login to user interface.....	22
4.5	Installing a license.....	23
4.6	Configuring high availability.....	25
4.7	Configuring MODBUS.....	25
4.8	Configuring PROFIBUS.....	26
Chapter 5	Connection to a controller.....	27
5.1	Modbus Mapping.....	27
5.1.1	Master status	27

5.1.2	Device information	28
5.1.3	Process data	30
5.1.4	Acyclic communication	31
5.1.5	High availability registers	33
5.1.6	Connection monitoring	35
5.2	Implementing Modbus with Unity Pro.....	35
5.3	Implementing Modbus with TIA Portal.....	35
Chapter 6	Asset Management.....	36
6.1	Setting device parameters with PACTware.....	36
6.1.1	Prerequisites	36
6.1.2	Configuring the PROFIBUS driver	36
6.1.3	Creating a project in PACTware	38
6.2	Setting device parameters with SIMATIC PDM.....	39
6.2.1	Prerequisites	39
6.2.2	Configuring the PROFIBUS driver	39
6.2.3	Connecting the SIMATIC Manager	39
Chapter 7	LED status indicators.....	43
7.1	Status LEDs (PWR, RUN, ERR and CFG).....	44
7.2	High Availability LEDs.....	45
7.3	Modbus LEDs (MB).....	45
7.4	PROFIBUS Master LEDs.....	46
Chapter 8	Using the web interface.....	47
8.1	General functions.....	47
8.2	Information.....	47
8.2.1	System	48
8.2.2	License	48
8.2.3	About	48
8.3	Settings	49
8.3.1	Network	49
8.3.2	User accounts	50
8.3.3	Firmware update	52
8.3.4	Reset	54
8.3.5	HTTPS certificates	54
8.3.6	Licensing	56
8.3.7	High Availability	57
8.4	Diagnosis	58
8.4.1	Settings	58
8.4.2	Logfile	59

8.4.3	Threads	60
8.4.4	Status	60
8.5	MODBUS TCP	61
8.5.1	Settings	61
8.5.2	Mapping	62
8.5.3	Log	62
8.6	PROFIBUS	63
8.6.1	Configuration	63
8.6.2	Log	64
Chapter 9	Declaration of conformity.....	65

This page is intentionally left blank.

1 About this guide

1.1 Read me first

Please read this guide carefully before using the device to ensure safe and proper use. Softing does not assume any liability for damages due to improper installation or operation of this product.

This document is not warranted to be error-free. The information contained in this document is subject to change without prior notice. To obtain the most current version of this guide, visit the Download Center on our website at: <http://industrial.softing.com/en/downloads>

1.2 Target audience

This guide is intended for experienced operation personnel and network specialists responsible for configuring and maintaining field devices in process automation networks. Any person using a Modbus Gateway must have read and fully understood the safety requirements and working instructions in this guide.

1.3 Typographic conventions

The following conventions are used throughout Softing customer documentation:

Keys, buttons, menu items, commands and other elements involving user interaction are set in bold font and menu sequences are separated by an arrow

Open **Start** → **Control Panel** → **Programs**

Buttons from the user interface are enclosed in brackets and set to bold typeface

Press **[Start]** to start the application

Coding samples, file extracts and screen output is set in Courier font type

```
MaxDlsapAddressSupported=23
```

Filenames and directories are written in italic

Device description files are located in C:
 \<Application
 name>\delivery\software\Device Description
 files



CAUTION

CAUTION indicates a potentially hazardous situation which, if not avoided, may result in damage or injury.



Note

This symbol is used to call attention to notable information that should be followed during installation, use, or servicing of this device.



Hint

This symbol is used when providing you with helpful user hints.



Video

This symbol indicates a video on the corresponding topic.

1.4 Document history

Document version	Changes since last version
1.00	First version
1.10	Description of 2-channel Modbus Gateway added.
1.11	Maximum permissible ambient temperatures changed for horizontal and vertical mounting of gateways. See Installation positions ¹⁴ for details.
1.20	Additional features including licensing and high availability added and related chapters and screenshots updated.
1.21	Connection diagrams modified, interface functions ⁴⁷ described and reference to Modus trademark added.
1.22	RJ45 status LEDs ⁴³ explained.
1.22-1	Communication port ¹⁹ details and operation mode PRM/CFG added to device information ²⁸ added.

1.5 Related documentation and videos

The following links provide additional product information:

- [Documents](#)
- [Videos](#)

1.6 Document feedback

We would like to encourage you to provide feedback and comments to help us improve the documentation. You can write your comments and suggestions to the PDF file using the editing tool in Adobe Reader and email your feedback to support.automation@softing.com.

If you prefer to write your feedback directly as an email, please include the following information with your comments:

- document name
- document version (as shown on cover page)
- page number

2 About the gateways

The Softing Modbus Gateway offers robust data mapping between a Modbus TCP server and a PROFIBUS master for easy connection of PROFIBUS network slave devices to a Modbus control system.

- The **mbGate PA** is available as a 2-channel model and a 4-channel model. Both models integrate PROFIBUS PA (**P**rocess **A**utomation) networks in Modbus systems at a fixed speed of 31.2 kbit/s. The 2-channel model supports up to 32 PROFIBUS PA devices and the 4-channel model up to 64 PROFIBUS PA devices. This gateway is typically used in areas of process automation with explosive atmosphere.
- The **mbGate PB** integrates PROFIBUS PA (**P**rocess **A**utomation) and PROFIBUS DP (**D**ecentralised **P**eripherals) networks in Modbus systems at speeds of up to 12Mbit/s. It maps two PROFIBUS PA and one PROFIBUS DP network segments supporting up to 32 PROFIBUS PA and 32 PROFIBUS DP devices. This gateway is typically used with a centralized controller in factory automation.
- The **mbGate DP** integrates one PROFIBUS DP (**D**ecentralised **P**eripherals) network with up to 32 PROFIBUS DP devices in Modbus systems at speeds of up to 12Mbit/s.

All three gateways support industry-standard device configuration, parameterization and condition-monitoring tools.

Engineering systems and asset management systems

The Modbus Gateway can be managed with the following tools:

- Modbus engineering system (e.g. Schneider Unity Pro, Siemens TIA Portal)
- FDT frame application (e.g. PACTware)
- Siemens SIMATIC PDM (Process Device Manager)

2.1 Intended use

This series of gateways has been designed to integrate PROFIBUS network slaves in Modbus TCP networks. Any other use is not intended. Follow the instructions in this document on how to configure and operate the gateways.



CAUTION

Do not use this device in hazardous areas! See Section [Specifications](#)¹⁴ for permissible ambient conditions.

2.2 Specifications

Power supply	18 VDC...32 VDC; SELV/PELV supply mandatory Typical input current is 200 mA; maximum is 1 A (considering the rush-in current at switch-on).
Ethernet	IEEE 802.3 100BASE-TX/10BASE-T
Minimum ambient operating temperature	-40 °C (see Installation positions ¹⁴ for the maximum ambient temperature depending on the mounting position)
Storage temperature	-40 °C...+85 °C
Altitude	must not exceed 2000 m
Location	indoor use only; no direct sunlight

2.3 Supported features

The Modbus Gateway supports the following features:

- Simple connection to PROFIBUS PA and PROFIBUS DP devices using Modbus controllers.
- Integration in FDT frame applications.
- Integration in Siemens SIMATIC PDM.
- Configuration of the gateway in a web browser.
- Integrated configurator to start up the PROFIBUS devices.
- Access to process values of PROFIBUS devices (input und output) in the Modbus control program.
- Access to operation state and Life Sign of the PROFIBUS devices in the Modbus control program.
- Changing of operation state of the PROFIBUS Master (STOP/RUN) in the Modbus control program.
- Acyclic reading and writing of device parameters in the Modbus control program.
- Detailed display of the operation state by LEDs.
- Two Ethernet interfaces (switched internally).
- Power supply by connectors or rail connectors.
- High Availability.

2.4 System requirements

This gateway can be used in combination with a Modbus engineering system such as Schneider Unity Pro or Siemens TIA Portal. When the gateway is used to parametrize PROFIBUS devices you need a Siemens SIMATIC PDM or an FDT frame application like PACTware. Also required are:

- 24V power supply
- one power conditioner per PROFIBUS PA segment
- field barrier (for Ex environment)
- PC with web browser
- GSD file for each PROFIBUS device on your network

2.5 Safety precautions



CAUTION

During operation, the device's surface will be heated up. Avoid direct contact. When servicing, turn off the power supply and wait until surface has cooled down.



Note

Do not open the housing of the Modbus Gateway. It does not contain any parts that need to be maintained or repaired. In the event of a fault or defect, remove the device and return it to the vendor. Opening the device will void the warranty!

3 Installation

3.1 Hardware installation



Note

With an ambient temperature above 55 °C at the place of installation it is very likely that the temperatures of connecting cables will increase if the cables are installed in an unfavourable position. In such cases, measure the temperature to ensure that the service temperature of the cables is not exceeded or use cables sustaining high temperatures of at least 90 °C.

3.1.1 Mounting and dismantling



Note

Make sure the Modbus Gateway is mounted in such a way that the power supply can be easily disconnected.



Note

Depending on the installation position, the maximum ambient operating temperature may differ. See Section [Installation positions](#) ¹⁴ for details.



Installation and inspection

Installation and inspection must be carried out by qualified personnel only (personnel qualified according to the German standard TRBS 1203 - Technical Regulations for Operational Safety). The definition of terms can be found in IEC 60079-17.

Mounting

1. Hook the upper notch of the cut-out on the back of the Modbus Gateway into a 35 mm DIN rail.
2. Press the Modbus Gateway down towards the rail until it slides into place over the lip of the locking bar.

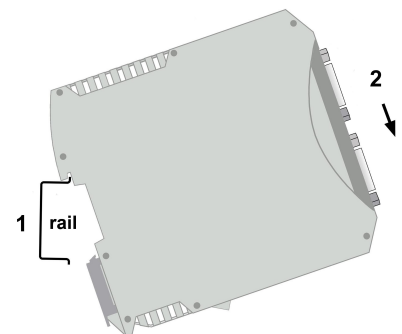

Note

Do not put stress on the system by bending or torsion.

Dismounting

1. Slide a screwdriver diagonally under the housing into the locking bar.
2. Lever the screwdriver upwards, pull the locking bar downwards - without tilting the screwdriver - and move the gateway upwards off the rail.

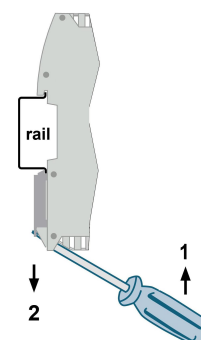

3.1.2 Connection diagrams mbGate PA

The mbGate PA is available as a 2-channel model and a 4-channel model. The 2-channel model has 2 physical PROFIBUS segment connections (PA0 to PA1) while the 4-channel model has 4 physical PROFIBUS segment connections (PA0 to PA3). By connecting two gateways over a redundancy link (RDL) you will obtain a higher uptime (high availability).

The gateway has two 10/100 Base-T Ethernet ports (ETH1/ETH2). Both RJ45 ports correspond to IEEE 802.3 and are connected to an internal switch for line topologies. The following diagrams show the side profile of the two mbGate PA models with the input and output interfaces and fieldbus connections at the bottom:

2-channel model

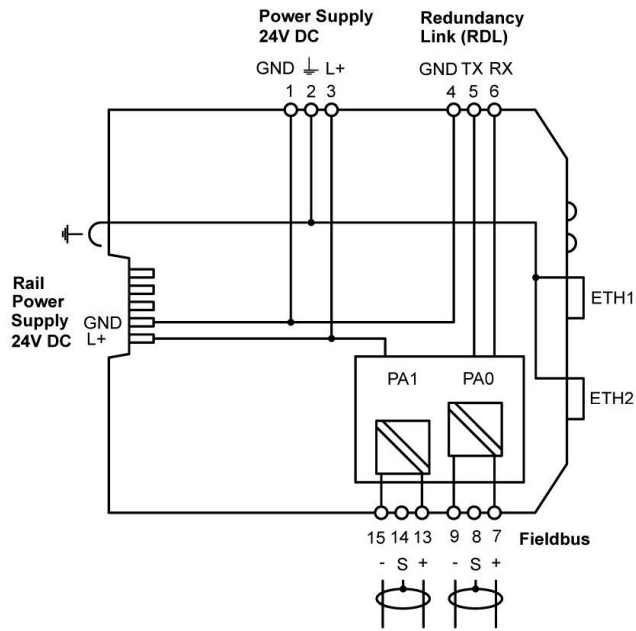

4-channel model

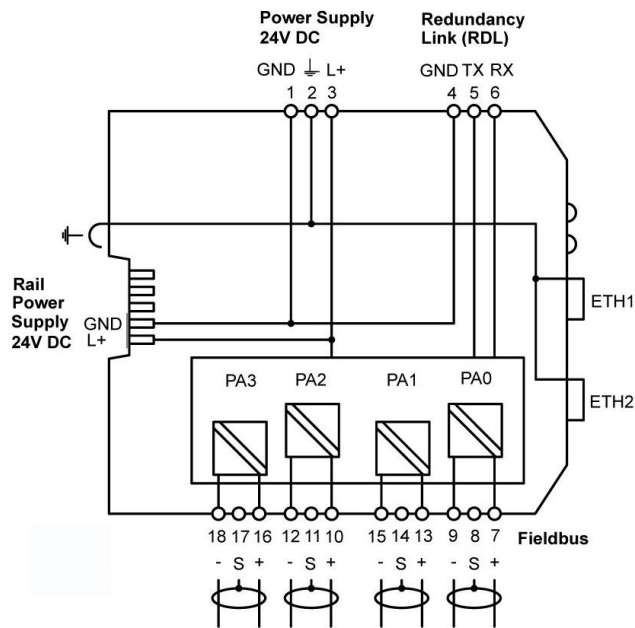

3.1.3 Connection diagram mbGate PB

The following diagram shows the input and output interfaces of the mbGate PB. It has two 10/100 Base-T Ethernet ports (ETH1/ETH2), two physical PROFIBUS PA segment connections (PA0 to PA1) and one RS-485 link for PROFIBUS DP data communication. By connecting two gateways over a redundancy link (RDL) you will obtain a higher uptime (high availability). The RJ45 ports correspond to IEEE 802.3 and are connected to an internal switch for line topologies. The following diagram shows the side profile of the mbGate PB model with the input and output interfaces and fieldbus connections:

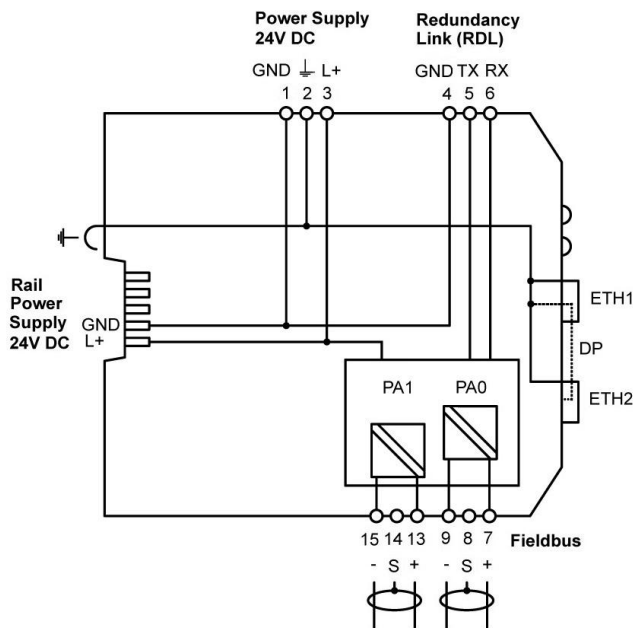

3.1.4 Connection diagram mbGate DP

The following diagram shows the input and output interfaces of the mbGate DP. The gateway has two 10/100 Base-T Ethernet ports (ETH1/ETH2) and one RS-485 link for PROFIBUS DP data communication. By connecting two gateways over a redundancy link (RDL) you will obtain a higher uptime (high availability). The RJ45 ports correspond to IEEE 802.3 and are connected to an internal switch for line topologies.

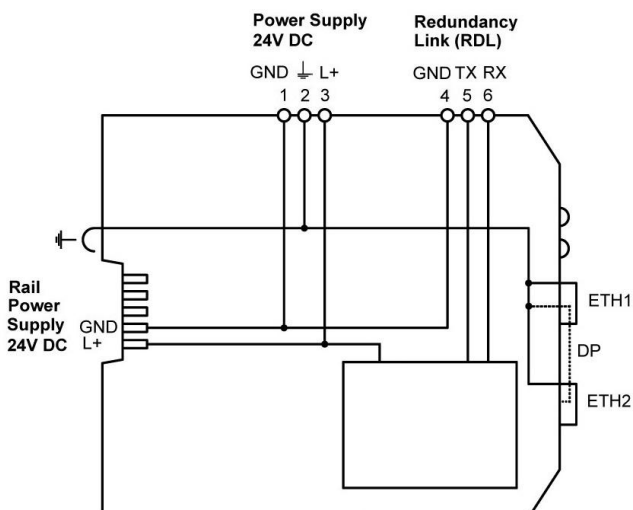

3.1.5 Connecting the power supply



Note

As the mbGate PA and mbGate PB does not supply power to the PROFIBUS PA connections, each PA segment of your PROFIBUS network requires its own power supply with power conditioning (such as power conditioner R.STAHL 9412).

Connect the gateway to a 24 V DC power supply. The supply voltage (18 VDC 32 VDC) is connected by a 3-pole terminal block. The power supply is connected to the plug connector via flexible wires with a cross section of 0.75 to 1.5 mm². The ground connection wire must have a cross section of 1.5 mm².

	Pin	Signal	Description
	1	GND	Ground
	2		Functional earth
	3	L+	Positive supply voltage



CAUTION

The Functional Earth (FE) connection of the device has to be connected at low inductance with the Protective Earth (PE) of the system.



Note

As the connection diagrams show, the power can also be applied by a special DIN rail connector (Rail Power Supply). For further information contact Softing Industrial Automation GmbH.



Note

See also the maximum ambient temperatures in the Section [Installation positions](#)¹⁴.

3.1.6 Installation positions

The Modbus Gateway can be mounted horizontally and vertically. Depending on the installation position, different ambient operating temperatures (T_a) are allowed.



Minimum distance

Provide a minimum distance of 50 mm to the air inlet and air outlet to ensure natural convection.



Rotated installation position

The maximum permissible ambient temperature values also apply to a 180° rotated installation position.

Horizontal installation position and maximum temperatures

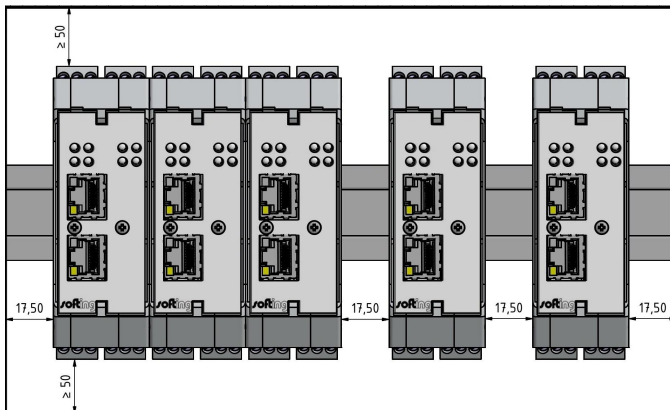

Number of PA channels used	Maximum PA fieldbus voltage	Minimum distance	Maximum ambient temperature T _a
0 - 4	32VDC	0 mm	50 °C
0 - 2*	24VDC	0 mm	55 °C
0 - 4	32VDC	17.5 mm	60 °C
0 - 2*	24VDC	17.5 mm	60 °C

* mbGate DP models have no PA channel

Vertical installation position and maximum temperatures

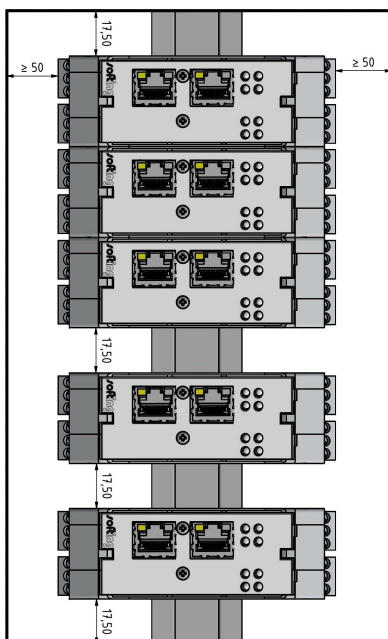

Number of PA channels used	Maximum PA fieldbus voltage	Minimum distance	Maximum ambient temperature T _a
0 - 4	32VDC	0 mm	40 °C
0 - 2*	24VDC	0 mm	45 °C
0 - 4	32VDC	17.5 mm	50 °C
0 - 2*	24VDC	17.5 mm	55 °C

* mbGate DP models have no PA channel

3.1.7 Connecting to the network

1. Connect each segment of your PROFIBUS network to a port of your gateway. Be sure that each segment is powered by a power conditioner. If you connect to field devices in explosive atmospheres ensure that you also connect a field barrier in between.
2. Connect the gateway from one of the two Ethernet ports with your Modbus network.
3. Connect the PC running the engineering and asset management tools using the second Ethernet port.

mbGate PA network topology (2-channel model)

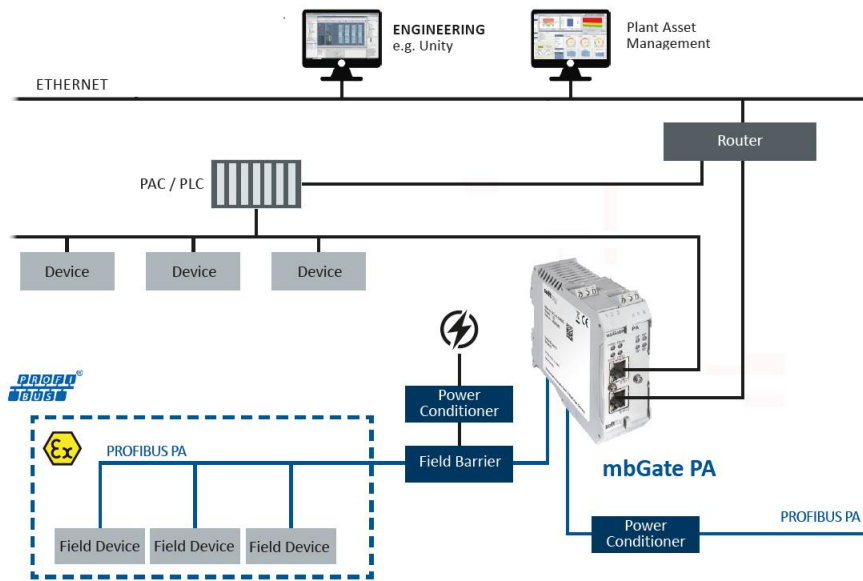

mbGate PB network topology

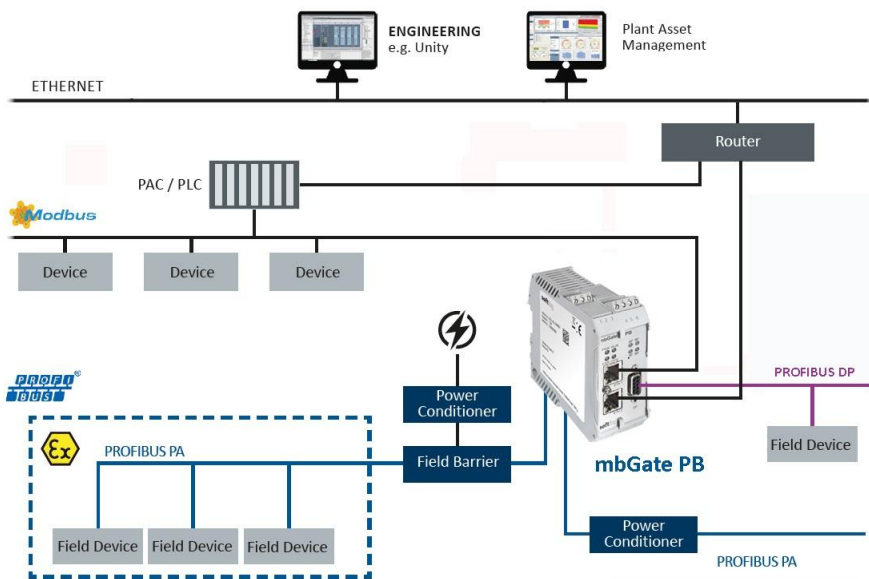

mbGate DP network topology

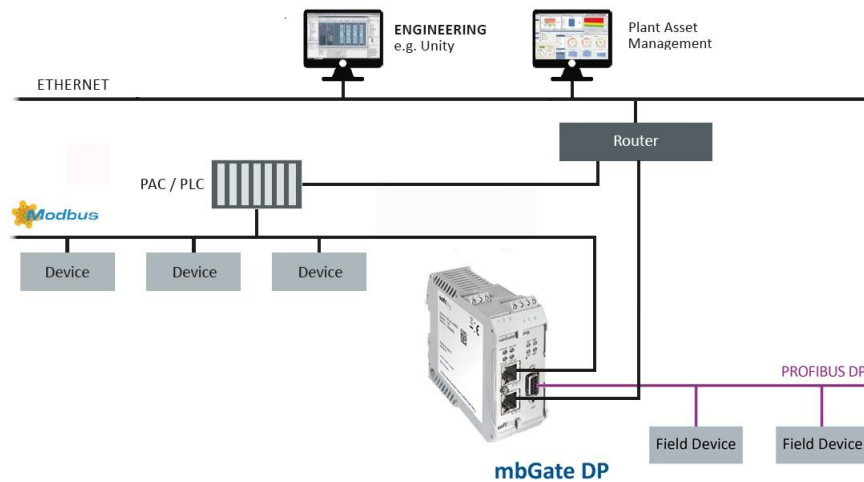

Example of Modbus high availability

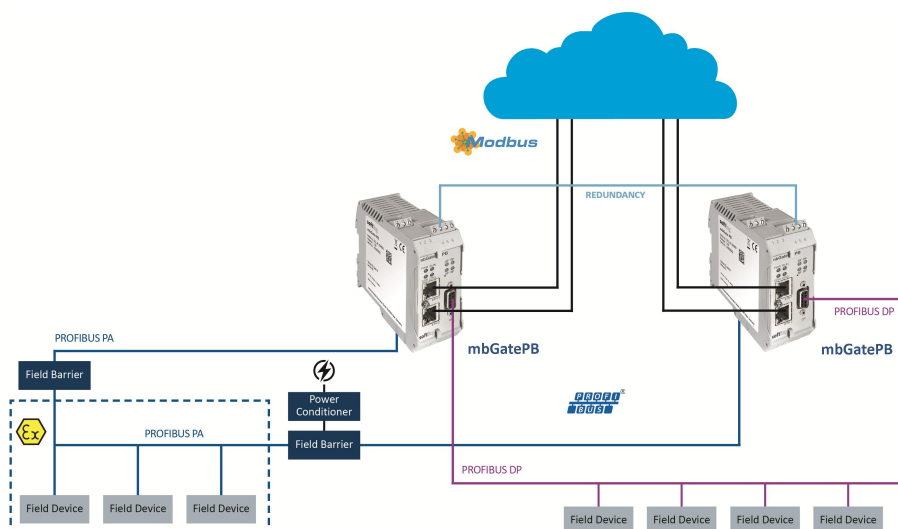

3.1.8 Powering up the device

Turn on the power supply. The boot process will take around 15 seconds. For indication of proper operation refer to [LED status indicators](#) ⁴³.

3.2 Software installation



Note

When you install a Softing product for the first time, you will be asked if you trust the publisher. Activate the option **Always trust software from Softing AG** if you do not want to be asked in subsequent installations and select **[Install]** to start the installation.

1. Go to the [mbGate web page](#) to download the latest product software.
2. Start by downloading and installing the **Search and Configure** tool.
3. Follow the on-screen installation instructions.
4. Read the license agreement carefully.
If you have questions, you can **[Cancel]** the installation at this point and contact us. Click **[Print]** if you want to print the license agreement to a PDF or on a printer.
5. Select **I accept the terms in the license agreement** and click **[Next]**.
6. Click **[Install]** to install the selected software application on your PC.
While the installation is in progress, the status bar of the installation wizard shows the different steps that are being executed. If you want to abort the installation, click **[Cancel]** button. The installation wizard will undo all modifications that have been made to your computer up to this point. Otherwise, wait until the installation is completed.
7. Press **[Finish]** to complete the installation and exit the wizard.



Note

Proceed with the installation of the other software packages.

Additional installations

Depending on your use case, install one of the following software packages:

- Install an FDT frame application (e.g. PACTware) if you are using FDT technology.
- Install **PROFIdtm** separately if you are not using PACTware but another FDT frame application like FieldCare or FieldMate.
- Install **PDM libraries** for integration into Siemens PDM.

4 Configuration

The Modbus Gateway comes with an integrated web server which is used to configure the gateway and the connected PROFIBUS devices. The default IP address of the integrated web server is 192.168.0.10. To access the Modbus Gateway from your PC, you either have to change the default IP address of the integrated web server to an address on your network or change the IP address on your PC to match the network address of your gateway (e.g. 192.168.0.1). Section [4.2](#)¹⁹ and Section [4.3](#)²¹ describe how to perform either of the two settings.

4.1 Prerequisites

- Ensure that you have downloaded and installed the latest firmware.
- The Modbus Gateway is connected to the PROFIBUS PA or PROFIBUS DP segment.
- The Modbus Gateway is connected with a PC which runs a standard Internet browser supporting JavaScript.
- GSD files (electronic device descriptions) corresponding to the PROFIBUS devices are available on the PC.
- The Search and Configure tool is installed.

Modbus Gateway requires the following communication ports to be available:

Application	Port	Port Type
Web Interface	80/443	TCP
Search and configure	1900, 2355, 5353	UDP/Multicast
PDM, DTM	2357	TCP
Modbus Communication	502 (default)	TCP

4.2 Changing the IP address of a gateway

Before you can operate the connected Modbus Gateway you will have to change the default IP address of your gateway so that your PC can communicate with the integrated web server over the Local Area Network.

The following steps apply to Windows 10.

1. Click **Start** → **Softing** → **Search and Configure**.
The application window is opened.

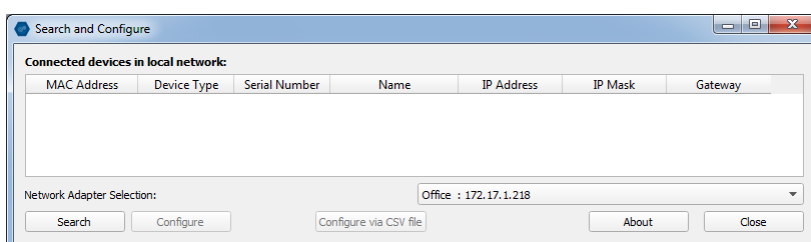

2. Click the dropdown list of the **Network Adapter Selection**.
This selection menu shows all networks you can access from your PC.
3. Select the network adapter which is connected to the gateway.
4. Click **[Search]** to start searching for connected gateways.
The search may take a moment.

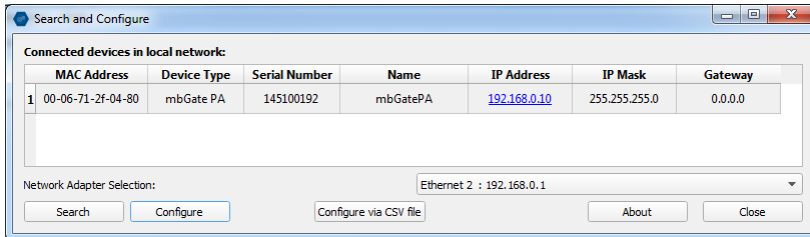

5. Select the gateway you want to configure.
6. Click **[Configure]** or double-click the device.
The configuration window opens. Here you can change the IP settings.

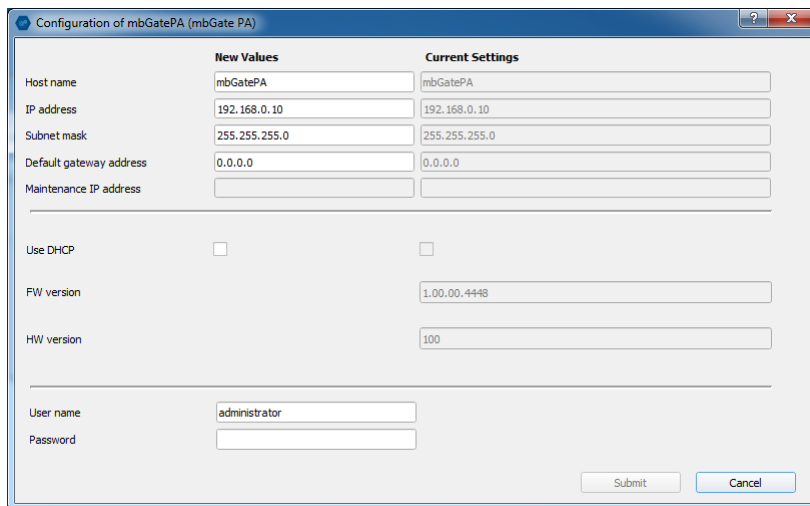

Note

You may also change the hostname. However, ensure that you follow hostname specifications RFC 952 and RFC 1123.

7. Enter a dedicated IP address and subnet mask or click **Use DHCP** to obtain the IP settings from a DHCP server.



Note

Ensure that you do not use the same IP address for Modbus communication and the web server of the gateway. You can change the IP address of the Modbus connection in the [web interface of the gateway](#)⁶¹.

8. Enter the default password **FGadmin!1** for username **administrator**.
9. Click **[Submit]**.
The changed settings are written to the device.

4.3 Setting the IP address of your PC

If you have not changed the IP address of the Modbus Gateway as described in the previous [Section](#)¹⁹ you will need to configure the IP address of your PC to access the gateway from your PC.

The following chapter describes how to set a static IP address in Windows 10.

1. Click **Start → Windows System → Control Panel** from your task bar.
2. Select **Network and Internet → Network and Sharing Center**.
A new window opens where you can view your basic network information.
3. Click on your Internet connection (either Ethernet or wireless) next to Connections under **View your active networks**.
A new window opens.
4. Click **[Properties]**.
5. Select **Internet Protocol Version 4 (TCP/IPv4)**.
The following window opens.

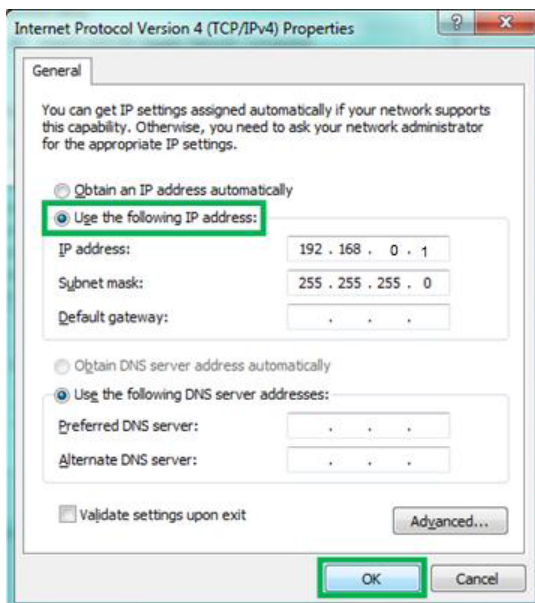

6. Select **Use the following IP address** and enter a specific IP address and Subnet mask. In our example we use the following settings:
 IP-Adresse: 192.168.0.1
 Subnet mask: 255.255.255.0
7. Click **[OK]** to confirm.

4.4 Login to user interface

1. Open your Internet browser and enter the IP address of your gateway.



Note

If you can't recall the IP address of your gateway, start the [Search And Configure](#) ¹⁹ tool to find out what it is (see Step 2 below).

2. Click the IP address of the gateway to launch the login window in your web browser.

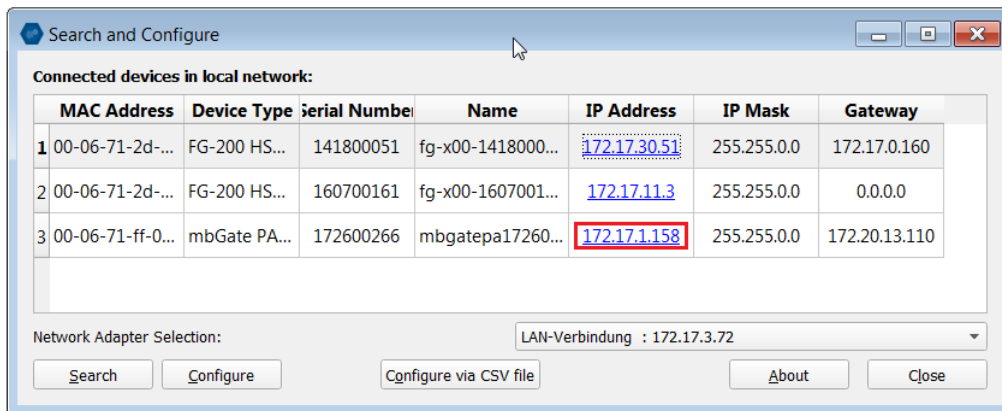

3. Select the administrator symbol and enter **FGadmin!1** in the password field.

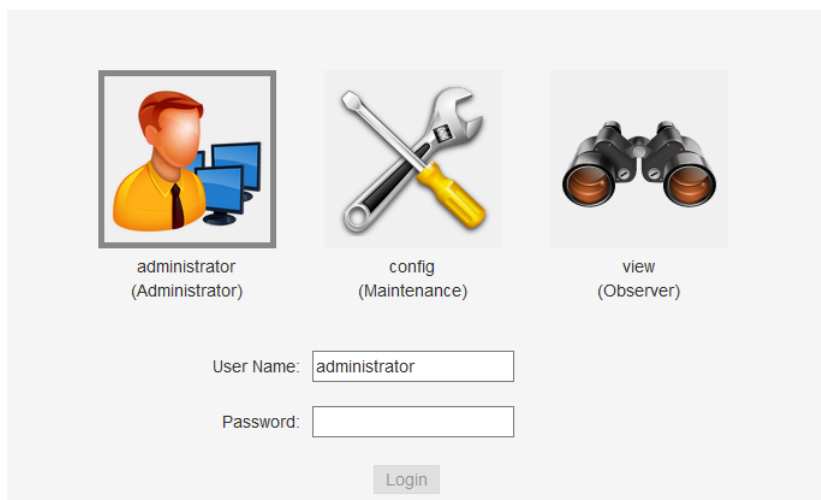

The gateway's web-based interface opens with the information page.

4.5 Installing a license

1. Go to the Softing Industrial website and click the icon in the upper right corner to register yourself or select this [My Softing Portal](#) link. When you are registered and logged in you are directed to My Softing Dashbord.
2. Click **[Register License]**.
3. Enter the license key on your License Certificate in the license key field. You will have received the License Certificate with the purchase of the licensed feature (like High Availability).
4. Log on to the user interface of the gateway and open the [Information](#) ⁴⁷ window of the device. Under **Information** → **System** you find the Host ID of your gateway.
5. Copy the Host ID and paste it into *Device/Host ID* field of the MY Softing Portal page.

Register License

Please enter your License Key and your Host ID. If you want to get notified in case of new releases, just check enable release info.

Activate License:

License Key

12345-ABCDE-67890-FGHIJ

Device/Host ID

Enable Release Info

Register License

Cancel

6. Click **[Register License]**. A license file is generated.
7. Click **[Download]** to save the license file to your PC.
8. Switch to the user interface of the gateway.
9. Select **Settings** and click **Licensing** in the side bar navigation

Name	Version	Options	End date
High Availability	-	-	-

10. Click **[Choose License File...]** and select the license file you downloaded to your computer. The license file you selected is shown beneath.

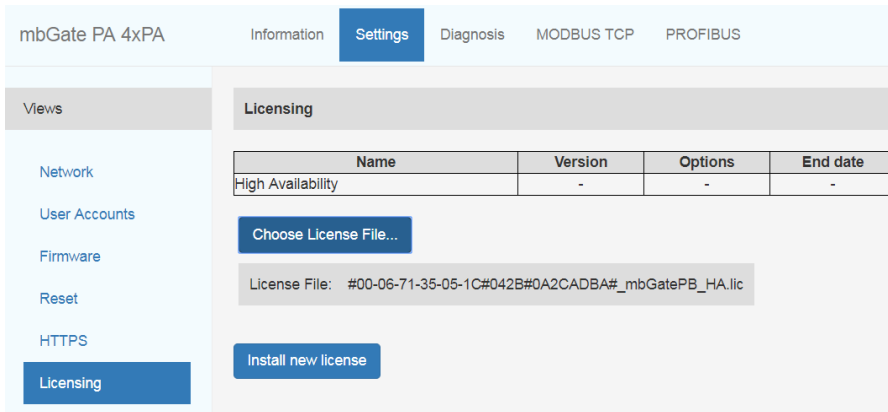

11. Click **[Install new licence]**.
The status column will prompt you to restart your gateway.
12. Click **[Restart Device]** in top menu bar left to the Logout option.

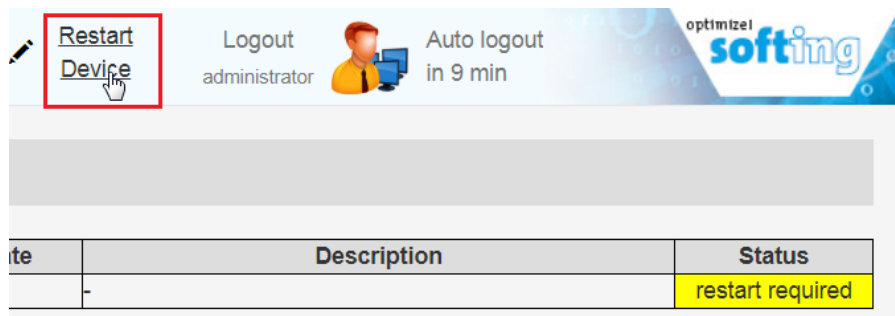

13. Click **[OK]** in the pop-up message window.
14. The restart of the device will take a few seconds. The user interface is reloaded automatically and you are redirected to the login page.
When you return to **Settings** → **Licensing** the status column indicates that the license has been successfully installed and the new licensed feature (here High Availability) appears in the sidebar menu.

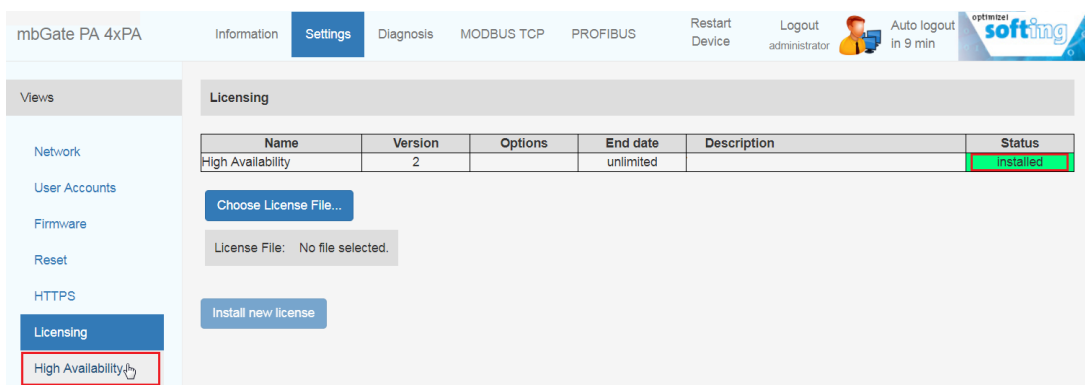

Note

New features (here High Availability) are shown in the sidebar menu.

4.6 Configuring high availability



Note

You will need to install a license to use the high availability feature. See Chapter [Installing a license](#) for details.

After you have installed the high availability license files you will need to assign a gateway tag and activate the redundancy mode.

1. Tick the checkbox **Activate**.

The screenshot shows the 'mbGate PB' web interface. The top navigation bar includes 'Information', 'Settings' (selected), 'Diagnosis', 'MODBUS TCP', and 'PROFIBUS'. On the left, a 'Views' sidebar lists 'Network', 'User Accounts', 'Firmware', 'Reset', 'HTTPS', 'Additional Features', and 'High Availability' (selected). The main content area is titled 'High Availability' and contains a red-bordered checkbox labeled 'Activate' which is checked. Below this is a text input field labeled 'Tag of gateway pair'. A note below the input field reads 'The new data is used after a restart of the device' and there is a blue 'Apply' button.

2. Enter the gateway tag.
The minimum length is 1 character. The maximum length is 32 characters.
The following characters are allowed: a-z A-Z - _ .
3. Click **[Apply]**.
4. Restart your Modbus Gateway.



Note

Repeat the steps above with the redundant device.

4.7 Configuring MODBUS

1. Select **MODBUS TCP** → **Settings**.
2. Enter a dedicated IP address and subnet mask or tick the checkbox **Obtain IP settings from DHCP server**.
3. Click **[Apply]**.
4. Click **[Restart Device]** in top menu bar left to the Logout option.

mbGate PA 4xPA Information Settings Diagnosis **MODBUS TCP** PROFIBUS

Views

- Settings
- Mapping
- Log

Modbus Settings

Obtain IP settings from a DHCP server

IP Address: 172.20.14.110 ✓

Subnet Mask: 255.255.0.0 ✓

Default Gateway: 0.0.0.0 ✓

Default TCP Port: 502

Additional TCP Port: 0 ✓

Watchdog [msec]: 0

The new data is used after a restart of the device

Apply

4.8 Configuring PROFIBUS



Note

As all three gateways have the same PROFIBUS master interface, the configuration instructions for mbGate PA also apply to mbGate PB and mbGate DP.



Video

Watch the video [PROFIBUS configuration](#) to find out how to configure the PROFIBUS master interface of your gateway.

mbGate PA 2xPA Information Settings Diagnosis MODBUS TCP **PROFIBUS** Restart Device Logout administrator Auto logout in 9 min

Views

- Configuration
- Log

Actions

- Import GSD
- Remove All GSDs
- Clear Configuration
- Load Configuration
- Save Configuration
- Create Report
- Export Unity Pro FBs
- Apply Configuration

Configuration

Device Catalog

Device Name	Manufacturer	Ident Number	GSD File Name	PA
DVC6200p Profibus PA	Emerson Process Management	0x1037	IC051037.gsd	+
FBK Starter Kit	Softing	0x0c5e	SF010C5E.gsd	+
PA-ROCK	Softing	0x0002	DPS_0002.gsd	+
PAeasy-HART/MOEB	Softing	0x1234	SF011234.gsd	+
PROMASS 83 PA	Endress+Hauser	0x152a	eh3_152a.gsd	+
ST100	FCI	0x0e00	01000e00.gsd	+

Segment Configuration

Segment PA0

- DVC6200p Profibus PA (Address: 3, Device Type: DVC6200p Profibus PA (Emerson Process Manager))
- FBK Starter Kit (Address: 4, Device Type: FBK Starter Kit (Softing))
- PA-ROCK (Address: 5, Device Type: PA-ROCK (Softing))

Analog Input: OUT (long) Slot: 1

Discrete Input: OUT_D Slot: 2

Analog Output: SP (long) Slot: 3

5 Connection to a controller

The following chapter describes how to establish a Modbus connection using the engineering systems Schneider Unity Pro and Siemens TIA Portal.

5.1 Modbus Mapping

The Modbus Gateway maps the statuses of the PROFIBUS masters and the PROFIBUS slaves to a number of Modbus registers. In addition, the gateway offers a register-based command interface for acyclic reading and writing of PROFIBUS device parameters.

Select **MODBUS TCP** → **Mapping**.

The screenshot shows the 'Modbus Mapping' configuration page for 'mbGate PA 4xPA'. The 'MODBUS TCP' tab is active. Under 'Views', 'Mapping' is selected. The main content area shows 'Segment PA0' selected. Below this, there is a section for 'FBK Starter Kit' with 'Address: 3' and 'Device Type: FBK Starter Kit'. A 'Status Register' is set to 8503. A table lists the modules and their register mappings:

Modules:	Name	Slot	Input Registers	Output Registers
	OUT (long)	1	0 H - 2 H	No output data
	OUT (long)	2	2 L - 4 L	No output data
	SP (long)	3	No input data	0 H - 2 H
	SP (long)	4	No input data	2 L - 4 L
	OUT_D	5	5 H - 5 L	No output data
	SP_D+RB_D	6	6 H - 6 L	5 H - 5 L

5.1.1 Master status

The operation mode of the PROFIBUS master can be read and changed in the low bytes of Modbus registers 8500, 8628, 8756 and 8884. The following diagram shows the Modbus registers used for the segments of different Modbus Gateway .

Register	mbGate PA – 4 CH	mbGate PA - 2 CH	mbGate PB	mbGate DP
8500	Status PA-0	Status PA-0	Status PA-0	Status DP-0
8628	Status PA-1	Status PA-1	Status PA-1	-
8756	Status PA-2	-	Status DP-0	-
8884	Status PA-3	-	-	-

When a PROFIBUS master is started it takes on the operation mode **Stop**. In this mode, PROFIBUS input data is read but no output data is written to the PROFIBUS slaves. If you want the PROFIBUS master to write output data to the PROFIBUS slaves, you must set the master to operation mode **Run** by writing value 3 to the corresponding Modbus holding register.

The following diagram shows the operation modes and corresponding values.

Operation mode	Value	Meaning
Offline	1	Cyclic data exchange is deactivated.
Stop	2	Cyclic data exchange is activated, but only input data is read (Fail Safe Mode).
Run	3	Cyclic data exchange is activated. Input data is read and output data is written.



Note

The PROFIBUS master cannot be set to Offline mode by writing into the status register.

5.1.2 Device information

The Modbus Gateway provides the status and the Ident number of the connected PROFIBUS devices.

The device status is provided per segment in a Modbus register for every device station address between 1 and 126. Station address 0 is assigned to the master. The register number of a specific station address is the sum of the base register number of the respective segment and the station address. The [base register numbers](#)²⁷ for the segments are 8500 (segment 0), 8628 (segment 1), 8756 (segment 2) and 8884 (segment 3). The register number for a device on station address 2 in the first segment is therefore 8502. The register number can also be found in the configuration report (see **Status Register** in image below). For details on how to generate a configuration report, see the video [PROFIBUS configuration](#)⁶³.

The high byte of the status register is the so called Life Sign. The value increases by 1 every time input data is read successfully from the device.

The Ident number of the devices is provided per segment in a Modbus register for every device station address between 1 and 126. Station address 0 is assigned to the master. The register number of a specific station address is the sum of the base register number of a segment and the station address. The base register numbers for the segments are 9012, 9140, 9268 and 9396. The register number for a device on station address 2 in the first segment is therefore 9014.

Device FBK Starter Kit

Address: 2
 Name: FBK Starter Kit
 Revision: 1
 Manufacturer: Softing
 Ident Number: 0C5E
 Status Register: 8502

The low byte of the status register represents the operation mode of the device. The following table shows the available operation modes with corresponding values and meaning:

Operation mode	Value	Meaning
PRM/CFG	3	Connection is being established.
Data Exchange	4	Cyclic data exchange is activated for the device.
Not Accessible	5	The selected station address is not assigned to any device or the device cannot be accessed.
Prm Fault	6	The device shows a parameterization error.
Cfg Fault	7	The device shows a configuration error.
Idle	8	Cyclic data exchange is deactivated for the device.

**Note**

The device status registers can be read both as input registers and holding registers while the Ident number registers can be read only as input registers.

5.1.3 Process data

The Modbus registers representing the process data of the PROFIBUS devices start with register number 0 for both input data and output data. While the input data is mapped to input registers the output data is mapped to holding registers. Input data and output data of a device are mapped contiguously to the Modbus registers. In other words the process data of a module can start or end in the middle of a register.

The registers to which the process data is mapped are found in the configuration report, listing the table **Slots** for each configured device with the columns **Input Registers** and **Output Registers**. See also chapter [PROFIBUS configuration](#)⁶³ and the related [video](#) for details on how to create a report.

Slots

Name	Number	Module	Input Registers	Output Registers
Analog Input 1	1	OUT (long)	0 H - 2 H	none
Analog Input 2	2	OUT (long)	2 L - 4 L	none
Analog Output 1	3	SP (long)	none	0 H - 2 H
Analog Output 2	4	SP (long)	none	2 L - 4 L
Discrete Input	5	OUT_D	5 H - 5 L	none
Discrete Output	6	SP_D+RB_D	6 H - 6 L	5 H - 5 L

In the example above the 5 bytes process data of **Analog Input 1** are mapped to registers 0 and 1 plus the high byte (first byte) of register 2. The letter **H** behind the start register number 0 indicates that the process data starts in the high byte of register 0. Similarly, the letter **H** behind the end register number 2 indicates that the process data ends in the high byte of register 2. The low byte (second byte) of register 2 is therefore not used by process data of this module.

The 5 bytes process data of **Analog Input 2** are mapped to the low byte (second byte) of register 2 and the registers 3 and 4. The letter **L** behind the register number indicates that the process data starts or ends in the low bytes of the registers. As a result of the contiguous mapping, register 2 includes both the last byte of the process data of the first module and the first byte of the process data of the second module.

The following diagram shows the mapping of the process data to the registers.

Input (Input Register)

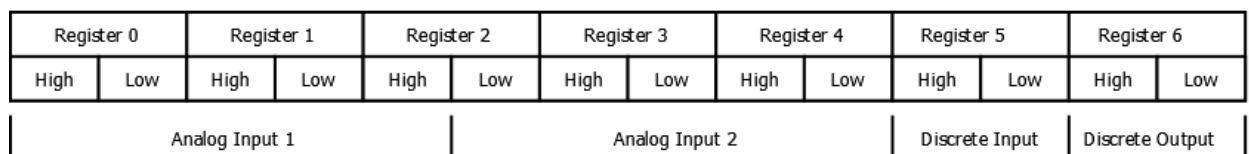

Output (Holding Register)

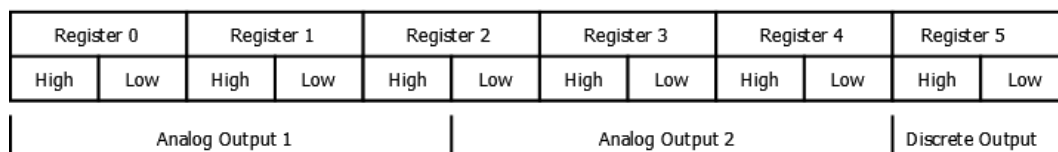

The process data of further devices start at the next register.

5.1.4 Acyclic communication

The Modbus Gateway has a register-based communication interface for acyclic reading and writing of PROFIBUS device parameters. There are 128 registers reserved per segment. The first 5 registers are control registers which are used to process the command protocol. The remaining 123 registers are used as data registers. The base register numbers for the segments are 9012, 9140, 9268 and 9396.



Note

The registers of the command interface can only be addressed as holding registers.

Acyclic reading

The controller initiates acyclic PROFIBUS reading by writing a specific command to the control registers of the command interface (see table below). The command must be written by consistent multiple register access.

Register	Value
base register + 0	1
base register + 1	station address of the PROFIBUS device
base register + 2	slot number within the device
base register + 3	parameter index within the slot
base register + 4	Maximum number of data bytes to be read. The maximum value is 246.

The gateway responds immediately to the writing access. Depending on whether the values in the control registers are valid writing access is granted or refused. If writing access is granted, the controller must read the control registers of the command interface by consistent multiple register access. The gateway will refuse reading access if the data which is to be read is not yet available. In this case the controller must repeat the reading access until access is granted. The following table shows which values are available in each register.

Register	Value
base register + 0	2
base register + 1	station address of the PROFIBUS device
base register + 2	slot number within the device
base register + 3	parameter index within the slot
base register + 4	actual number of data bytes

The controller must now read the device data from the data registers of the command interface by consistent multiple register access. The first data register which is read is always base register + 5. The last data register which is read depends on the length of the data the gateway provides in base register + 4 and results in base register + 5 + (data length / 2). The following table shows the arrangement of the data registers.

Register	Value
base register + 5	first and second byte of the read data
base register + 6	third and fourth byte of the read data
base register + 7	fifth and sixth byte of the read data
...	

The first, third, fifth, ... byte is located in the high byte of a register. The second, fourth, sixthbyte is located in the low byte of a register.

Acyclic writing

The controller initiates acyclic PROFIBUS writing by writing a specific command to the control registers of the command interface and writing the data to the data registers. The last data register to be written depends on the length of the data and is calculated as $\text{base register} + 5 + (\text{data length} / 2)$. It is important that command and the data are written by consistent multiple register access.

Register	Value
base register + 0	3
base register + 1	station address of the PROFIBUS device
base register + 2	slot number within the device
base register + 3	parameter index within the slot
base register + 4	Number of bytes of data to be written. The maximum value is 246.
base register + 5	first and second byte of data to be written
Basisregister + 6	third and fourth byte of data to be written
Basisregister + 7	fifth and sixth byte of data to be written
...	

The first, third, fifth, ... byte must be in the high byte of the register while the second, fourth, sixth, ... byte must be in the low byte of the register.

The gateway responds immediately to the writing access. Depending on whether the values in the control registers are valid, writing access is granted or refused.

5.1.5 High availability registers

Using a primary gateway and a backup gateway as redundant pair increases the overall availability of a system. The redundant role of a gateway is controlled by the Modbus registers 9990 to 9993. By reading the error state in register 9993 and the status information in register 9991, a redundancy switching mechanism can be implemented in the PLC. For this purpose, the target state of one of the gateways is reset by writing to register 9990. The other gateway then automatically enters into the complementary status. This is true with one exception: If the redundancy link is interrupted, the status of both devices must be set accordingly.

This chapter describes which registers are available specifically for redundancy (high availability), how to read the redundancy state and how to read the error state. If an error occurs, the program running on the PLC can decide to switch to primary, backup or fail-safe mode.



Note

The gateways do not automatically switch to redundancy mode when an error condition occurs. By writing to register 9990, one gateway is set to a certain node state (PRIMARY STOP, PRIMARY RUN, BACKUP), while the other gateway enters into the corresponding complementary state when the redundancy link is up.

Register	Register Type	Meaning
9990	Holding Register	<p>This register represents the redundancy state of the gateway.</p> <p>HighByte: always zero</p> <p>LowByte : Node State</p> <p>The register content is provided in byte ordering big-endian.</p> <p>NodeState:</p> <ul style="list-style-type: none"> ▪ 0x01 PASSIVE (PROFIBUS mode OFFLINE) ▪ 0x02 PRIMARY STOP (PROFIBUS mode CLEAR) ▪ 0x03 PRIMARY RUN (PROFIBUS mode OPERATE) ▪ 0x04 BACKUP (PROFIBUS mode STOP) ▪ 0x08 IN PROGRESS <p>NOTE: The write access controls the state of the PROFIBUS masters of all channels. The state can switch between BACKUP, PRIMARY STOP and PRIMARY RUN mode.</p> <p>PRIMARY STOP (fail-safe mode) reads only input data from the PROFIBUS devices.</p> <p>PRIMARY RUN reads input data and writes output data from/to the devices. By using the operation modes PRIMARY RUN and PRIMARY STOP, the PLC can ensure that the input data is read at least once before the output data is propagated to the device.</p> <p>After the register has been written it is recommended to read it back until the read value is the same as the requested one. This is needed due to the latency of the change of the redundancy role.</p>
9991	Holding Register	<p>This register represents the redundancy state.</p> <p>NOTE: Write access for this register area is ignored. The content of this register uses the same values as described for register Holding register 9990.</p>

<p>9992</p>	<p>Holding Register</p>	<p>This register represents the detected error state of the gateway which can be used to determine the error conditions.</p> <p>NOTE: Write access for this register is ignored.</p> <p>HighByte: Location HighByte / LowByte : Error state The register content is provided in byte ordering big-endian.</p> <p>Location:</p> <ul style="list-style-type: none"> ▪ 0x01nn local ▪ 0x02nn fieldbus ▪ 0x03nn PLC connection ▪ 0x04nn HA-system <p>State (Location local):</p> <ul style="list-style-type: none"> ▪ 0x0101 wrong state detected ▪ 0x0102 memory allocation failed <p>State (Location fieldbus):</p> <ul style="list-style-type: none"> ▪ 0x0201 no peer partner ▪ 0x0202 one or more slaves leave data-exchange ▪ 0x0203 no slave detected at fieldbus ▪ 0x0204 configuration of fieldbus could not be loaded ▪ 0x0205 fieldbus operate ▪ 0x0206 fieldbus stop/clear ▪ 0x0207 fieldbus offline <p>State (Location PLC connection):</p> <ul style="list-style-type: none"> ▪ 0x0301 no connection to PLC established ▪ 0x0302 watchdog expired <p>State (Location HA-System):</p> <ul style="list-style-type: none"> ▪ 0x0401 no peer partner ▪ 0x0402 versioning issue (RDL version) ▪ 0x0403 peer partners are not correctly assigned ▪ 0x0404 versioning issue (Baugruppentype) ▪ 0x0405 versioning issue (hardware revision) ▪ 0x0406 versioning issue (serial number) ▪ 0x0407 RDL livesign gap ▪ 0x0408 RDL livesign expired
<p>9993</p>	<p>Holding Register</p>	<p>This register represents the detected error state of the redundant gateway.</p> <p>NOTE: Write access for this register is ignored. The content of this register uses the same values as described for register Holding register 9992.</p>

5.1.6 Connection monitoring

The Modbus register 9998 can be used to monitor the connection between the PLC and the gateway. The value written to the register represents a timeout in milliseconds. Writing a value above 0 to the register means that the connection status is monitored with the set millisecond time frame. If the gateway notices that the register is not read or rewritten within the time frame defined by the value the error state “watchdog expired” is set in the gateway.

In redundant systems the error state is also set in the redundant gateway (see [high availability registers](#)³³).



Note

Once the watchdog is activated it can not be deactivated by writing value 0.

In non-redundant systems with only one gateway, setting a watchdog timer entails that the PROFIBUS master is set to STOP mode when the watchdog expires. The STOP mode corresponds to a fail-safe mode.

In redundant systems running with two gateways the PROFIBUS master of the different segments is not automatically set to operation mode STOP. Instead, the error state must first be detected by the redundant gateway. The PLC must track this register and must take appropriate action when the error state “watchdog expired” is detected .

Register	Register Type	Meaning
9998	Modbus watchdog register	This register represents a timeout in milliseconds (ms) and is used to monitor connections between the PLC and the gateway.

5.2 Implementing Modbus with Unity Pro



Video

Watch the video [Modbus configuration with Unity Pro](#) for details on how to configure the Modbus Gateway in Unity Pro to access the process data of the PROFIBUS devices via Modbus.

5.3 Implementing Modbus with TIA Portal



Video

Watch the video [Modbus configuration with TIA Portal](#) for details on how to address the Modbus Gateway in TIA Portal to the process data of the PROFIBUS devices via Modbus.

6 Asset Management

6.1 Setting device parameters with PACTware

6.1.1 Prerequisites

- The default IP address of the built-in web server has been changed to an address on your network or the IP address of your PC has been changed to an IP address corresponding to the network address of your gateway (e.g. 192.168.0.1). See Chapter [Setting the IP address of the PC](#)²¹.
- PACTware 4.1 or any other FDT frame application is installed.
- PROFIdtm is installed.
- Users of Windows 7 who have disabled the automatic update service must check if Microsoft hotfix KB3033929 is installed.
Open a command line, click **[Start]**, type **cmd** and in the command window that opens, type **wmic qfe|find "3033929"**.
The answer contains information about the time, date and Internet address of the installation.

6.1.2 Configuring the PROFIBUS driver

1. Click the Windows **Start button** to open the start menu.
2. Select **Softing PROFIBUS → Drivers and API → Runtime System → Driver Configuration** to configure the PROFIBUS driver.

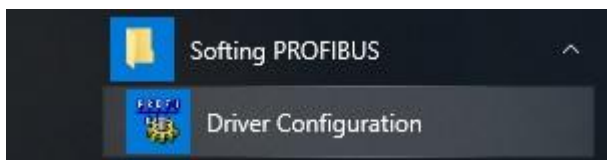

3. Allow Windows User Account Control (UAC) to modify settings.
The **PROFIBUS Control Panel** is opened.
4. Double-click **pnGate PB / mbGate PB**.
The PROFIBUS access window **Select Node Name** is opened.
5. Enter a symbolic node name (default value is Node0).
6. Click **[Continue]**.
The window **Select Addresses for pnGate PB / mbGate PB** is opened.
7. Enter the IP address for Modbus Gateway (**192.168.0.10** in our example).
8. Select a bus segment.

9. Click **[Continue]**.
The window **Select Timeouts for pnGate PB / mbGate PB** is opened.
10. Set timeouts for Modbus Gateway (Timeout for Connect and Max Idle Time). In most cases default settings can be used.
11. Click **[Apply]**
The configuration wizard is closed. In the **Control Panel** the node name is shown on the left side underneath **pnGate PA / mbGate PA**. The question mark on a yellow background means that the connection to the Modbus Gateway has not yet been tested.
12. Click **[Apply]** in the **PROFIBUS Control Panel** to save all settings and confirm with **[Yes]**.
The PROFIBUS Control Panel tests the connection to the Modbus Gateway. After a short while, the yellow question mark is replaced by a green check mark. If a red cross appears instead, check the network cables and the IP settings of your PC and the mbGate PA/mbGate PB/mbGate DP. Ensure that the PC and the Modbus Gateway are on the same IP subnet.

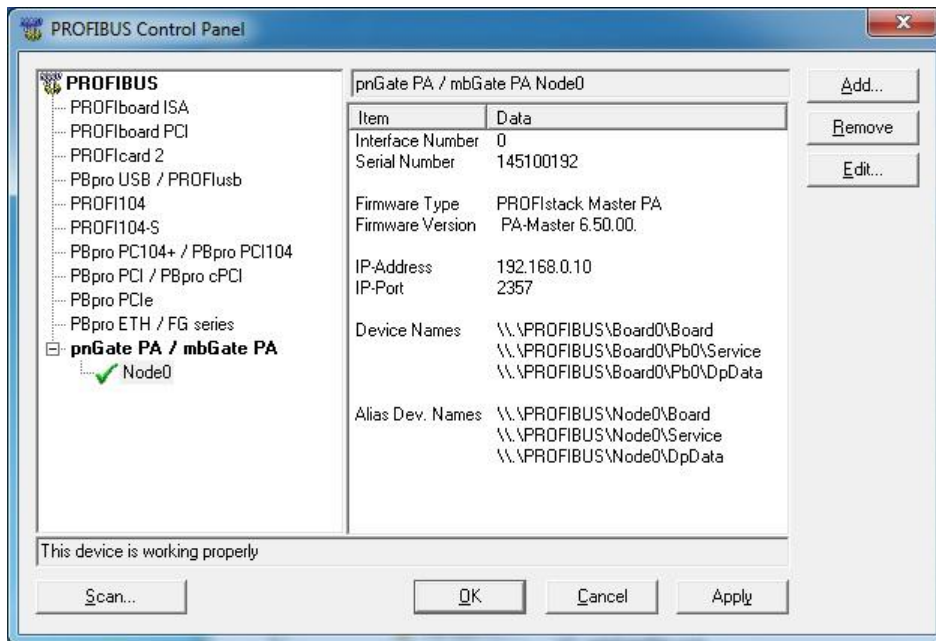

13. Click **[OK]** to close the **PROFIBUS Control Panel**.

6.1.3 Creating a project in PACTware

1. Start PACTware.
2. Create a new Project and save the project.
3. Right-click **Host PC** → **Add Device** in the device tag column of the project view.

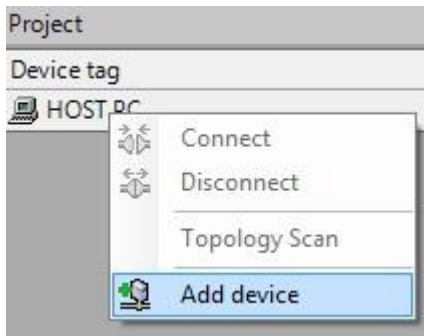

A new window appears with the available devices.

4. Select **PROFIdtmDPV1** from the list and confirm with **[OK]**. The device is displayed in the project view.



Note

Before starting a topology scan make sure the corresponding Device DTM is installed.

5. Right-click **PROFIdtm** and select **Topology Scan**.
6. Click the arrow in the scan window to start the topology scan.



PROFIdtm and the PA device are displayed in the project view.

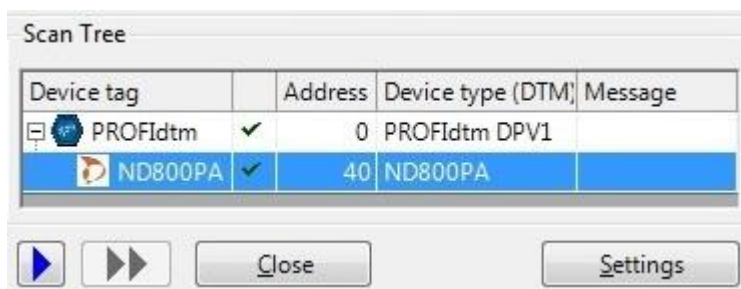

7. Close the scan window. The device is now included in the project view.

6.2 Setting device parameters with SIMATIC PDM

6.2.1 Prerequisites

- Users of Windows 7 who have disabled the automatic update service must check if Microsoft hotfix KB3033929 is installed.
Open a command line, click **[Start]**, type **cmd** and in the command window that opens, type **wmic qfe | find "3033929"**.
The answer contains information about the time, date and Internet address of the installation.
- EDD files and libraries of the PA devices must be imported in the PDM Device Integration Manager. If not available, download them from the Siemens support website and import them in the DIM.
- The PDM libraries of the Softing PROFIBUS must have been downloaded from the [mbGate product website](#) and must be installed.

6.2.2 Configuring the PROFIBUS driver

See Section [Configuring the PROFIBUS driver](#)³⁶ in the Chapter above.

6.2.3 Connecting the SIMATIC Manager

Connecting the SIMATIC Manager with the mbGate PB device:

1. Start the SIMATIC Manager from the Windows start menu to create a new project: **Start → All Programs → Siemens Automation → SIMATIC → SIMATIC Manager**.
2. Click **Options → Select PG/PC Interface**.
A new window with a dropdown menu is opened.
3. Select from the dropdown menu **Interface Parameter Assignment used → Softing PROFIBUS Interface PROFIBUS.1**.
4. Set the timeout value to 60s and confirm with **[OK]**.
5. Click the **[Properties...]** button.
A new window is opened.
6. Check the board number to ensure that it corresponds to the number in the node name.
(See Step 6 in Section [Configuring the PROFIBUS driver](#)³⁶)
7. Close both windows with **[OK]**.
You will return to the main window (Component View).



Note

A logical connection has been established between the mbGate PB and the SIMATIC Manager.

8. Go to **View → Process Device Network View**.

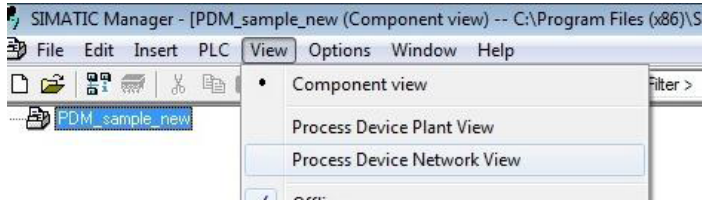

- Right-click on the configuration symbol in the Process Device Network View and select **Insert New Object** → **networks**.

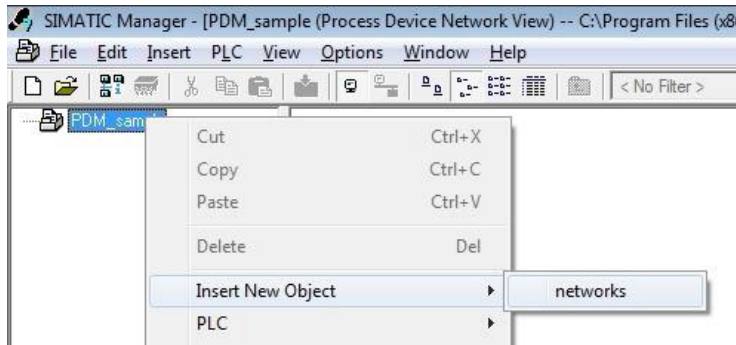

- Right-click on the network symbol and select **Insert New Object** → **Communication network**.

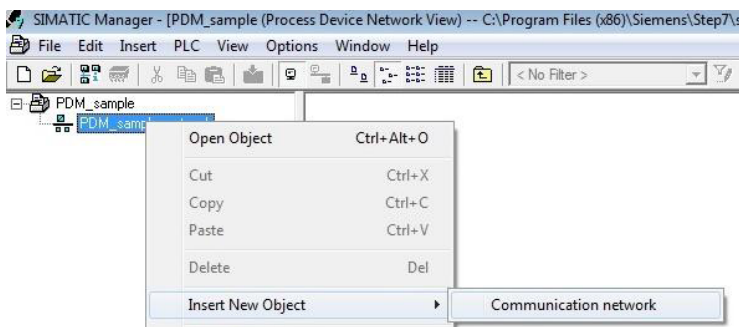

- Click the **[Assign Device Type...]** button. The Assign Device Type window is opened.
- Select **PROFIBUS DP network**.

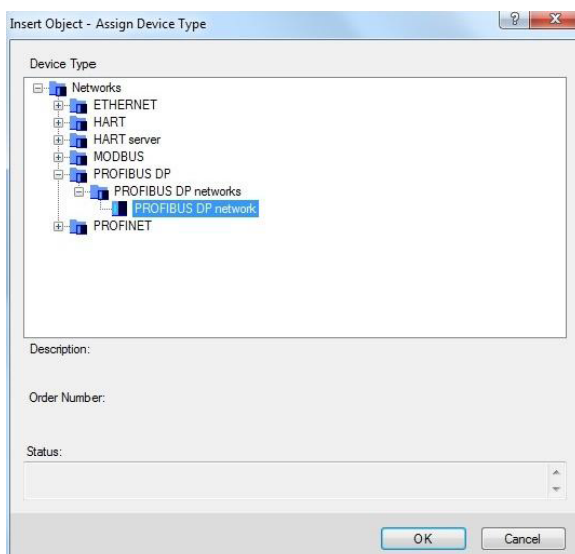

13. Click **[OK]** .
You are back in the Process Device Network View.
14. Right-click in the left column **PROFIBUS DP network** → **SIMATIC PDM** → **Start LifeList**.

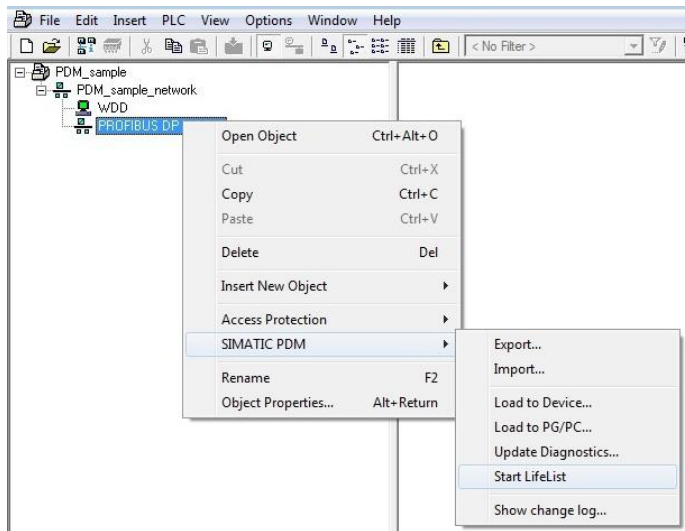

15. Click the **Start Scan** icon (▶) in the top left corner under the menu bar.
This will run a network scan to verify that the PA device can be reached.
The icon (▶) indicates that a device can be reached to read and write process parameters.

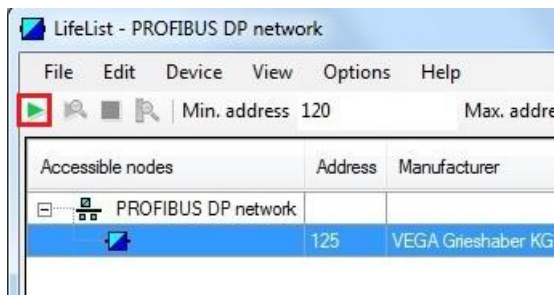

16. Close the window in the top right corner (X)
17. Right-click in the PROFIBUS DP network view and select **Insert New Object** → **Object**.

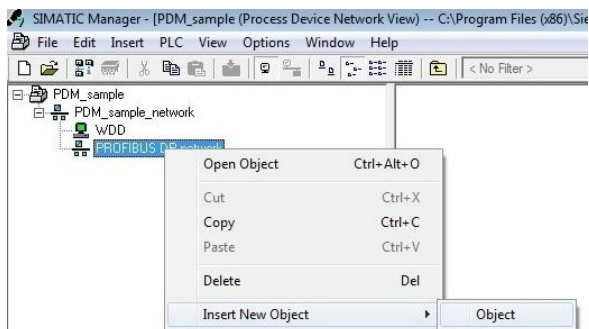

18. Click the **[Assign Device Type...]** button.
A new window opens.

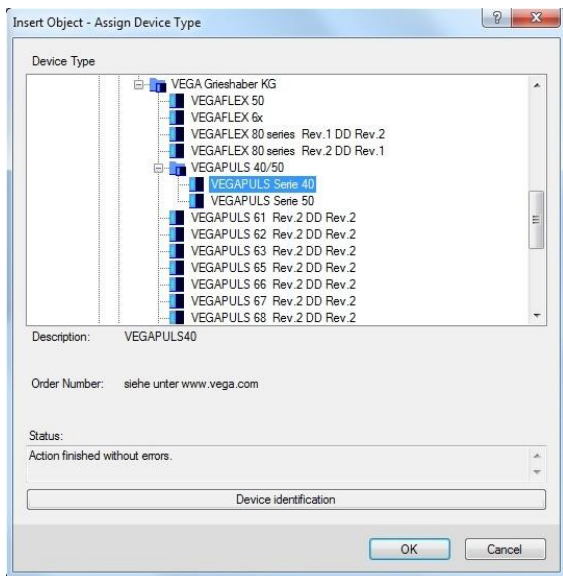

19. Select the device you want to access from the device type list and click **[OK]**.
20. Enter the PROFIBUS address.
21. Click **[OK]** to confirm.
The window is closed.
22. Right-click in the Process Device Network View on the device you have just selected and select **Object**.
This opens the SIMATIC PDM view which shows the parameter values of the selected device.
23. Click the Measured Value Display icon () underneath the menu bar to import the parameter values of the PA device to the Process Device Manger.

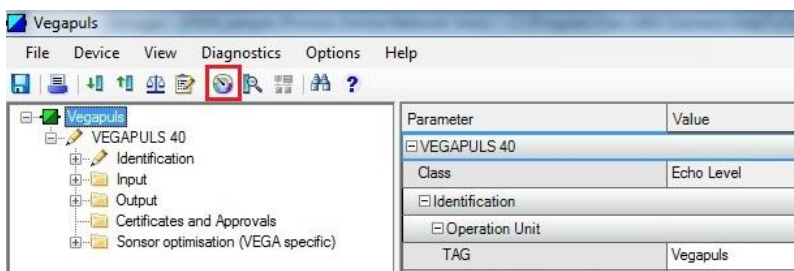

7 LED status indicators

The Modbus Gateway displays eight device status LEDs and two RJ45 connection status LEDs on the front side:

Device status LEDs

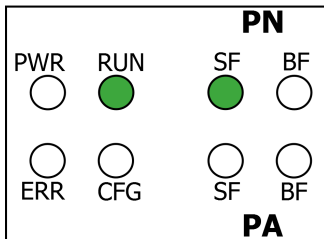

RJ45 status LEDs

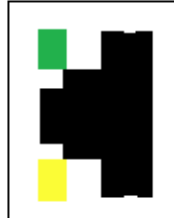

- PWR** = power supply - refer to [next section](#) ⁴⁴
- RUN** = running - refer to [next section](#) ⁴⁴
- ERR** = error - refer to [next section](#) ⁴⁴
- CFG** = configuration - displays configuration upload - refer to [next section](#) ⁴⁴
- SF** = system faults - displays Modbus/PROFIBUS system faults (wrong configuration, internal error, ...) - refer to [Modbus LEDs \(MB\)](#) ⁴⁵ and [PROFIBUS Master LEDs \(PA\)](#) ⁴⁶
- BF** = bus faults - displays Modbus/PROFIBUS bus faults - refer to [Modbus LEDs \(MB\)](#) ⁴⁵ and [PROFIBUS Master LEDs \(PA\)](#) ⁴⁶





















































































The device status LEDs are permanently on or flash in different colors and frequencies as indicated below:



























Symbol	Color	Lighting
	none	off
	red	permanent
	green	permanent
	red	flashing (1 Hz)
	red	flashing quickly (5 Hz)
	green	flashing (1 Hz)
	green	flashing slowly (0.5 Hz)
	green	flashing quickly (5 Hz)

The RJ45 status LEDs indicate the following behaviour:









Symbol	Color	Lighting
	green	permanent when Ethernet connection is on
	yellow	flashing when Ethernet connection is active

7.1 Status LEDs (PWR, RUN, ERR and CFG)

























LEDs	Meaning						
<table border="1"> <tr> <td>PWR </td> <td>RUN </td> </tr> <tr> <td></td> <td></td> </tr> <tr> <td>ERR</td> <td>CFG</td> </tr> </table>	PWR 	RUN 			ERR	CFG	<p>Start-up phase (approximately 10 seconds) 24V DC power supply is ok.</p>
PWR 	RUN 						
							
ERR	CFG						
<table border="1"> <tr> <td>PWR </td> <td>RUN </td> </tr> <tr> <td></td> <td></td> </tr> <tr> <td>ERR</td> <td>CFG</td> </tr> </table>	PWR 	RUN 			ERR	CFG	<p>Operating system starts (approximately 2 seconds)</p>
PWR 	RUN 						
							
ERR	CFG						
<table border="1"> <tr> <td>PWR </td> <td>RUN </td> </tr> <tr> <td></td> <td></td> </tr> <tr> <td>ERR</td> <td>CFG</td> </tr> </table>	PWR 	RUN 			ERR	CFG	<p>Device is running in factory mode (only firmware update is possible)</p>
PWR 	RUN 						
							
ERR	CFG						
<table border="1"> <tr> <td>PWR </td> <td>RUN </td> </tr> <tr> <td></td> <td></td> </tr> <tr> <td>ERR</td> <td>CFG</td> </tr> </table>	PWR 	RUN 			ERR	CFG	<p>Device is running/operational</p>
PWR 	RUN 						
							
ERR	CFG						
<table border="1"> <tr> <td>PWR </td> <td>RUN </td> </tr> <tr> <td></td> <td></td> </tr> <tr> <td>ERR</td> <td>CFG</td> </tr> </table>	PWR 	RUN 			ERR	CFG	<p>Software error A software error occurred. Reboot the device.</p>
PWR 	RUN 						
							
ERR	CFG						
<table border="1"> <tr> <td>PWR </td> <td>RUN </td> </tr> <tr> <td></td> <td></td> </tr> <tr> <td>ERR</td> <td>CFG</td> </tr> </table>	PWR 	RUN 			ERR	CFG	<p>Permanent hardware fault detection during startup A fatal error has been detected.</p>
PWR 	RUN 						
							
ERR	CFG						
<table border="1"> <tr> <td>PWR </td> <td>RUN </td> </tr> <tr> <td></td> <td></td> </tr> <tr> <td>ERR</td> <td>CFG</td> </tr> </table>	PWR 	RUN 			ERR	CFG	<p>Software error occurred, device has restarted automatically and error is reported in log file</p>
PWR 	RUN 						
							
ERR	CFG						

LEDs	Meaning						
<table border="1"> <tr> <td>PWR </td> <td>RUN  / </td> </tr> <tr> <td></td> <td></td> </tr> <tr> <td>ERR</td> <td>CFG</td> </tr> </table>	PWR 	RUN  / 			ERR	CFG	Firmware update is running (in factory mode if RUN LED blinking red)
PWR 	RUN  / 						
							
ERR	CFG						
<table border="1"> <tr> <td>PWR </td> <td>RUN </td> </tr> <tr> <td></td> <td></td> </tr> <tr> <td>ERR</td> <td>CFG</td> </tr> </table>	PWR 	RUN 			ERR	CFG	No power on device Check power supply.
PWR 	RUN 						
							
ERR	CFG						











7.2 High Availability LEDs

LEDs	Meaning	
<table border="1"> <tr> <td>RUN </td> </tr> </table>	RUN 	RUN Led with 1 Hz green: HA is enabled and PB Masters are in Offline or primary mode
RUN 		
<table border="1"> <tr> <td>RUN </td> </tr> </table>	RUN 	RUN Led with 0.5 Hz green: HA is enabled and PB Masters are in backup mode
RUN 		
<table border="1"> <tr> <td>RUN </td> </tr> </table>	RUN 	RUN Led with 1 Hz red: Problem with communication to redundancy partner or partner missing.
RUN 		

7.3 Modbus LEDs (MB)

LEDs	Meaning		
<table border="1"> <tr> <td>SF </td> <td>BF </td> </tr> </table>	SF 	BF 	No connection to a Modbus client The communication between the gateway and Modbus client is interrupted.
SF 	BF 		
<table border="1"> <tr> <td>SF </td> <td>BF </td> </tr> </table>	SF 	BF 	Connection establishment Time period the system needs to establish a connection; devices cannot yet communicate with each other.
SF 	BF 		
<table border="1"> <tr> <td>SF </td> <td>BF </td> </tr> </table>	SF 	BF 	Connected to the controller All devices are exchanging data.
SF 	BF 		
<table border="1"> <tr> <td>SF </td> <td>BF </td> </tr> </table>	SF 	BF 	Error in the Modbus part of the device An error such as a software error or a licence error has occurred.
SF 	BF 		

7.4 PROFIBUS Master LEDs

LEDs	Meaning
 SF  BF	<p>All channels offline</p>
 SF  BF	<p>All devices exchange data on all channels</p>
 SF /  BF	<p>At least one used channel is not online</p>
 SF  BF / 	<p>At least one slave is not in data exchange (BF: green - all channels are online; red: not any channel is online.)</p>
 SF  BF	<p>Error in the PROFIBUS part of the device An error such as a software error or a license error has occurred.</p>

8 Using the web interface

8.1 General functions

All interface windows display the following three functions:



Restart Device

Select this function to restart the gateway remotely as instructed in this user guide or whenever required in ongoing operation.

Logout

Select this function to log out as an active user.

Auto logout

This function automatically logs out the current user from the gateway if the interface is inactive for a certain amount of time (as indicated in minutes).

8.2 Information

The **Information** window shows detailed product-related information in the menus **System**, **License** and **About**, including the type of gateway hardware, version, bootloader and firmware of your gateway.

mbGate PA 4xPA		Information	Settings	Diagnosis	MODBUS TCP	PROFIBUS	
Views	Device / System						
	System	Serial Number	170700218				
	License	Firmware Version	1.20.00.7543				
	About	Bootloader Version	1.04.01.4927				
		Factory Version	1.03.00.4927				
		Hardware Version	1.00				
		System ID	mbGate PA 4xPA				
		Host ID	#00-06-71-35-05-1C#042B#0A2CADBA#				
		Motherboard					
		Serial Number	164800218				
		Hardware Version	1.00				
		Daughterboard					
		Serial Number	164800218				
	Hardware Version	1.00					

8.2.1 System

Select **Information** → **System** to view the hardware and software details of your device.

Parameter	Meaning
Serial Number	Serial number of the gateway.
Firmware Version	Version of the currently running firmware.
Bootloader Version	Version number of the boot loader.
Factory Version	Version number of the factory image.
Hardware Version	Version number of the hardware.
System ID	Gateway type = mbGate PA, mbGate PB or mbGate DP.
Host ID	This is the ID you will need to generate, install and activate a high availability licence.

8.2.2 License

Select **Information** → **License** to view the licenses used by the gateway firmware under an [open source license](#).

8.2.3 About

Select **Information** → **About** to show information about Softing and other useful information.

8.3 Settings

8.3.1 Network

Select **Settings** → **Network** to view and change the TCP/IP settings.



Note

You need to be logged in as [administrator or configurator](#)⁵⁰.

mbGate PA 4xPA Information **Settings** Diagnosis MODBUS TCP PROFIBUS

Views

- Network**
- User Accounts
- Firmware
- Reset
- HTTPS
- Licensing

TCP/IP Settings

Obtain IP settings from a DHCP server

IP Address: 172.17.1.245 ✓

Subnet Mask: 255.255.0.0 ✓

Default Gateway: 0.0.0.0 ✓

Hostname: mbgatepa-170700218.local ✎

NTP Server:

Enable discover services

The new data is used after a restart of the device

Apply

Parameter	Meaning
Obtain IP address from a DHCP server	The Dynamic Host Configuration Protocol (DHCP) is activated and the IP address is obtained from a DHCP server.
IP address	Internet Protocol (IP) address of the device used for web access.
Subnet mask	Subnet mask of the device used for web access.
Default gateway	Default gateway of the device used for web access.
Hostname	Name of the device used by a name server.
NTP Server	IP address of a Network Time Protocol (NTP) server used for time synchronisation.
Enable discover services	The Simple Service Discovery Protocol (SSDP) is enabled. This service is used to identify the device from external tools such as <i>Search and Configure</i> .
Apply	Click [Apply] to confirm changes made in this window.



Note

If you change the settings you must restart the gateway.

8.3.2 User accounts

In this section you will learn how to change accounts and passwords.

1. Select **Settings** → **User Accounts**.

As administrator you can change and confirm the passwords for different roles. See details below.

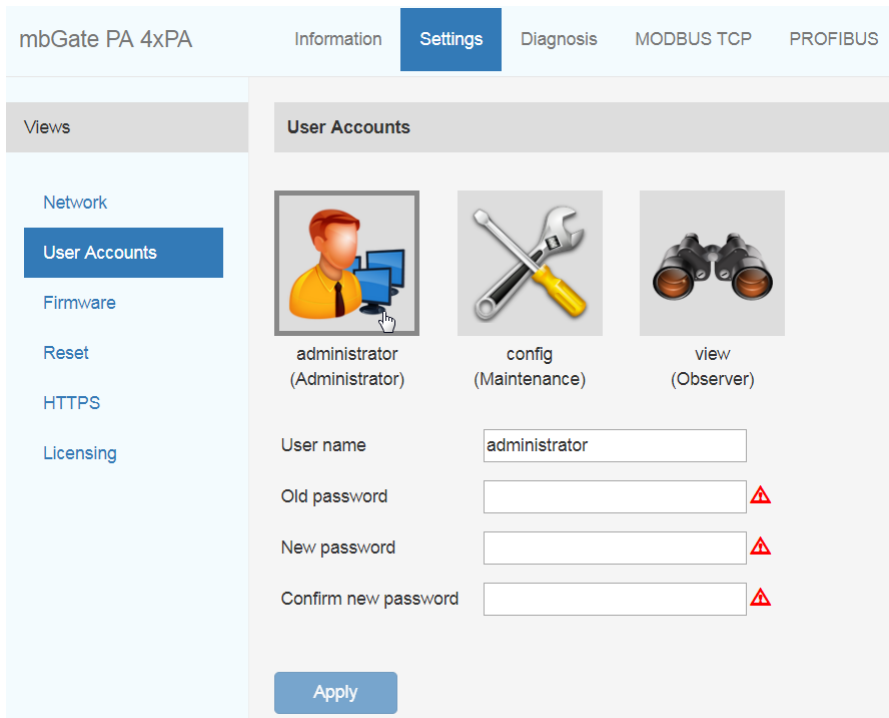

2. Click one of the icons (administrator, config or view) and enter the **Old Password** and the **New Password** in the corresponding fields.

3. Retype the password in the **Confirm new password** field and click **[Apply]** to save the modified password.

Access to your Modbus Gateway configuration tool is managed by user roles where each role has certain permissions. The following user roles are available:

Role	Username	Password
Administrator	administrator	FGadmin!1
Maintenance	config	FGconfig!1
Operator	view	FGview!1
Expert*	expert	FS-QsHnc7BWa{6w<
Diagnostics*	diagnosis	?<fJ#\/\$eB2qtGd*

* Backdoor accounts for Softing Support access. Currently supporting same features as administrator account.

The following table shows the permissions/actions of each user role:

Action	Admin / Diagn. / Exp.	Maintenance	Operator
Setting password	<input checked="" type="checkbox"/>		
Configuring gateway	<input checked="" type="checkbox"/>	<input checked="" type="checkbox"/>	
Reading configuration	<input checked="" type="checkbox"/>	<input checked="" type="checkbox"/>	<input checked="" type="checkbox"/>
Reading diagnostics	<input checked="" type="checkbox"/>	<input checked="" type="checkbox"/>	<input checked="" type="checkbox"/>

8.3.3 Firmware update

The gateway comes with pre-installed firmware which is maintained and updated to continuously enhance the functionality of the device. To ensure that your Modbus Gateway is always running the most recent version check the Softing [Download Center](#) for the most recent firmware update.



Note

You need to be logged in as [administrator](#)⁵⁰.

1. Download the firmware update to your computer.
When you are downloading from this site for the first time you will have to register yourself in a few steps.
2. Log on to the web interface of the gateway.
3. Select **Settings** → **Firmware** in the side bar navigation.

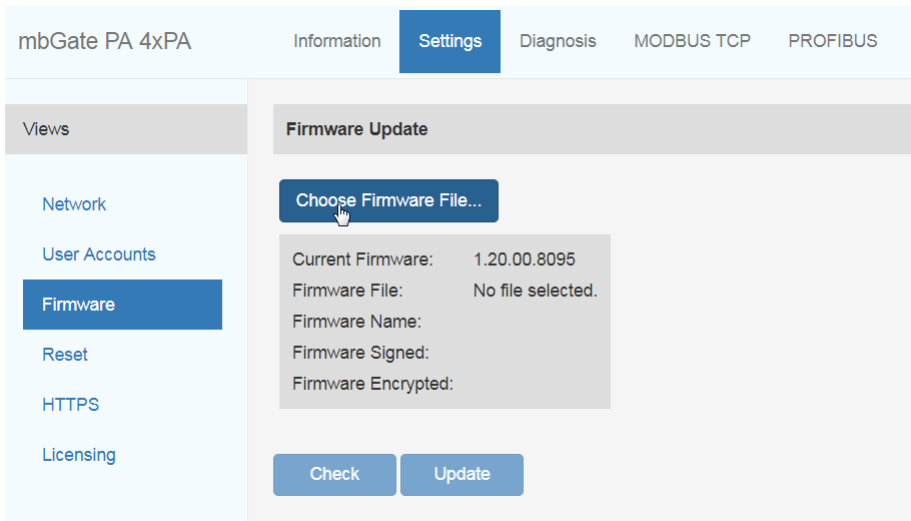

4. Click **[Choose Firmware File...]** and select the file *firmware.bin* from the firmware update you downloaded.

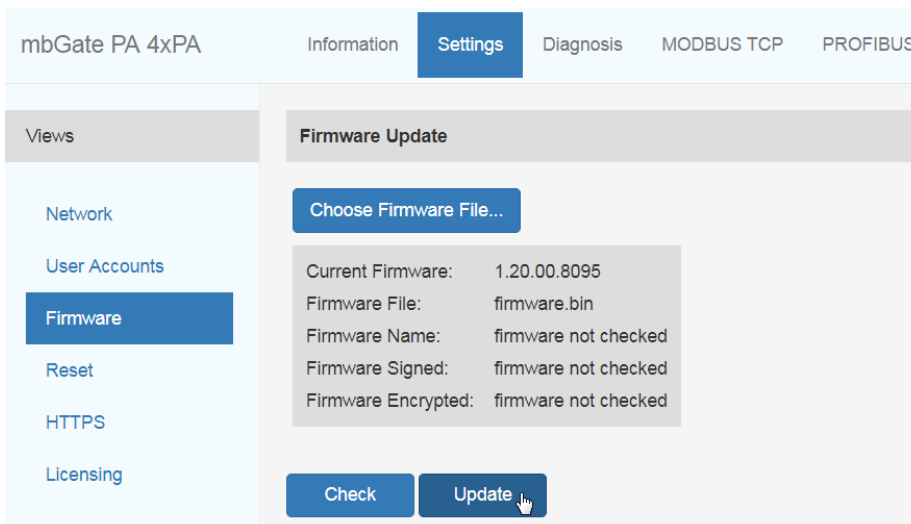

5. Click **[Update]** to install the latest firmware and **[OK]** in the message window. The update progress is shown beneath the update button.

**Hint**

Click **[Check]** to verify, if the file you have chosen is a valid firmware file.

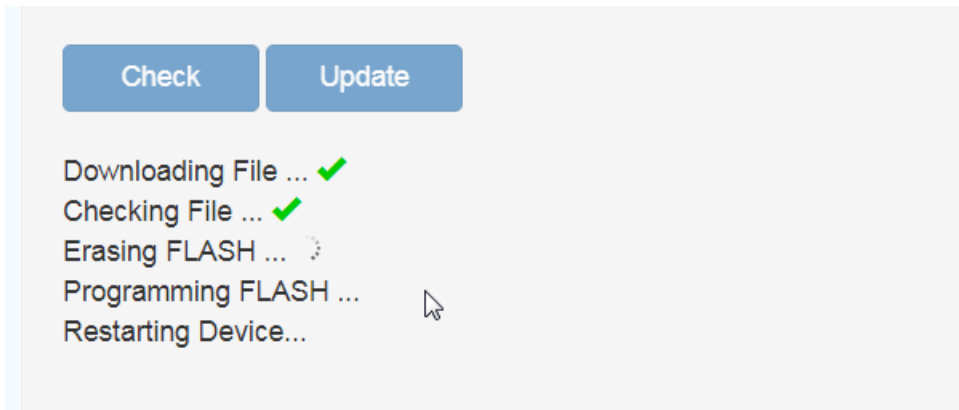

The system performs a firmware file check. The download starts automatically. When the download is completed the Modbus Gateway will be rebooted. When the boot process is completed, the RUN LED is ON.

**Note**

After the gateway has rebooted you are automatically forwarded to the log in page. If this fails please reload the web page.

**Note**

If anything goes terribly wrong during the firmware update you can always repeat the firmware update.

8.3.4 Reset

1. Select **[Erase Configuration]** to reset your device to default settings.



Note

You need to be logged in as [administrator](#)⁵⁰.

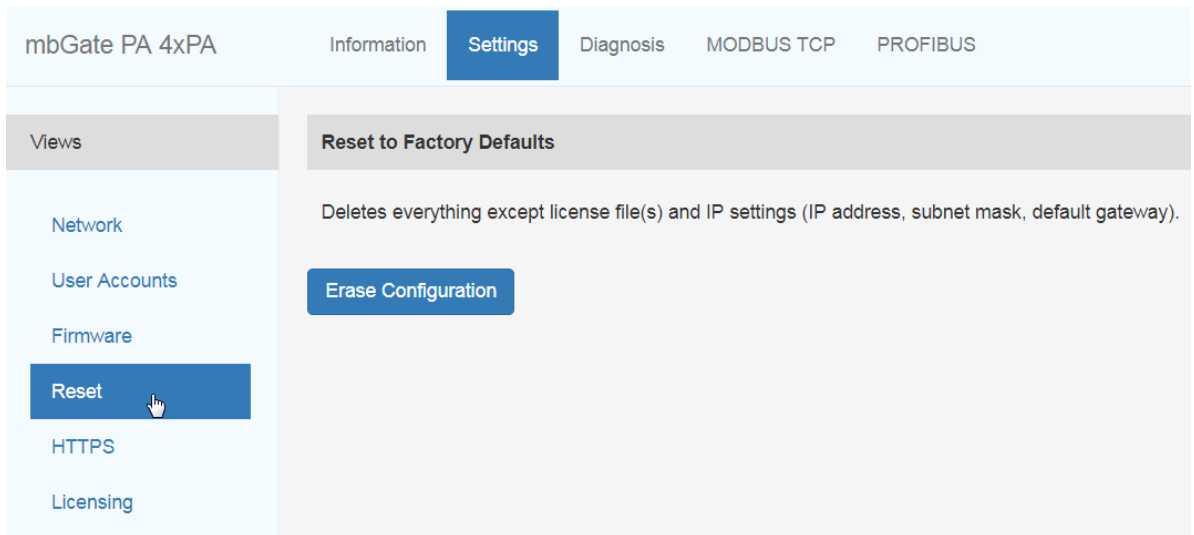

2. Click **[OK]** to confirm your selection.
Your Modbus Gateway will be restarted with the default settings. License files and IP settings will not be deleted.

8.3.5 HTTPS certificates

If you access your gateway on an HTTPS connection, make sure the gateway uses a trusted certificate. You can check easily if the IP address of your gateway is secured by a certificate. Depending on the settings of your web browser, Chrome, Explorer, and Firefox typically display a padlock icon in the address bar to indicate that a secured HTTP connection is used. Click on the icon to find out which type of security and certificate is used.

All three gateways use Open SSL V1.0.2 for TLS 1.2. If you want to use a different certificate to secure your gateway, select **Settings** → **HTTPS** and choose the upload options to install a private key, server certificate file or intermediate certificate file.

When you configure the HTTPS settings, the initially installed self-signed certificate is replaced. You can restore the original certificate by resetting the default gateway configuration (**Settings** → **Reset** → **Erase Configuration**).



Note

You need to be logged in as [administrator](#)⁵⁰ to change the HTTPS settings.

Parameter	Meaning
Choose private key file...	Install the private key file, containing the private key, generated simultaneously with the certificate signing request.
Choose server certificate file...	Install the server certificate file.
Choose Intermediate Certificate Files...	Optional for installing necessary intermediate certificate files.
Apply	Click button to activate your settings.

**Note**

If you change the settings you must restart the gateway.

**Note**

If you are experiencing problems with certificates, please update your web browser first with the most recent version before contacting Softing support.

**Note**

As your web browser might use cached data, please refresh the browser after rebooting the gateway.

8.3.6 Licensing

Select **Settings** → **Licensing** and follow the description on how to [install a license](#) ²³.



Note

You need to be logged in as [administrator](#) ⁵⁰.

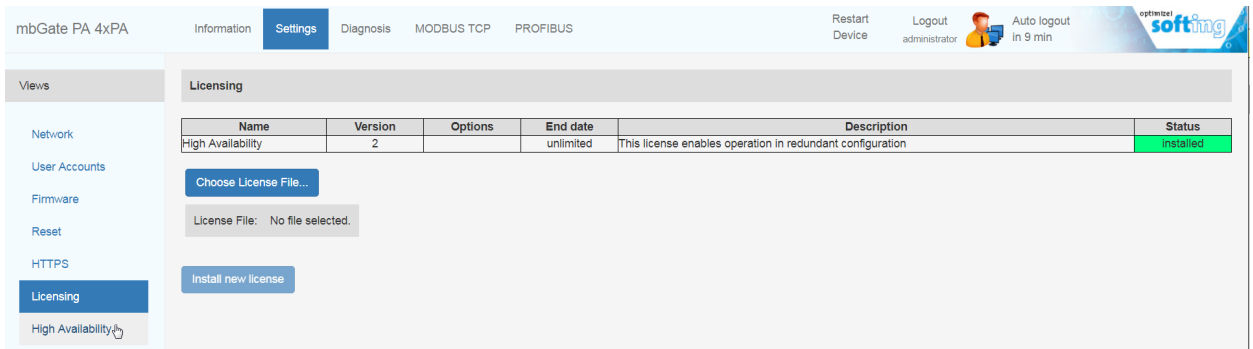

Parameter	Meaning
Name	Name of the feature to be licensed.
Version	Version of the license.
Options	A license might have different options. These are displayed here.
End date	Expiration date of the license.
Description	Description of the licensed feature.
Status	Status of the licensed feature.
Choose License File	Select a file via file selection dialog.
License File	Currently selected file.
Install new license	Button to install selected license.

8.3.7 High Availability

The High Availability option is available after you have installed the [license file](#)²³, selected the *Activate* option and entered the tag of the gateway pair.

The screenshot shows the 'mbGate PB' web interface with the 'Settings' tab selected. The 'High Availability' section is visible, featuring an unchecked checkbox labeled 'Activate' (highlighted with a red box), a text input field for 'Tag of gateway pair', and an 'Apply' button. A note below the input field states: 'The new data is used after a restart of the device'.

Parameter	Meaning
Activate	Tick checkbox to select high availability for a redundant gateway pair
Tag of gateway pair	Name of the gateway pair.
Apply	Click button to activate your settings.



Note

If you change the settings you must restart the gateway.

8.4 Diagnosis

Select **Diagnosis** → **Settings** to view gateway settings and log file values.



Note

The menu **Diagnosis** including all submenus **Settings, Logfile, Threads, Status** are reserved for Softing Support to help Expert users analyse system data.

8.4.1 Settings

Select **Diagnosis** → **Settings** to view gateway settings and change your log file priority.

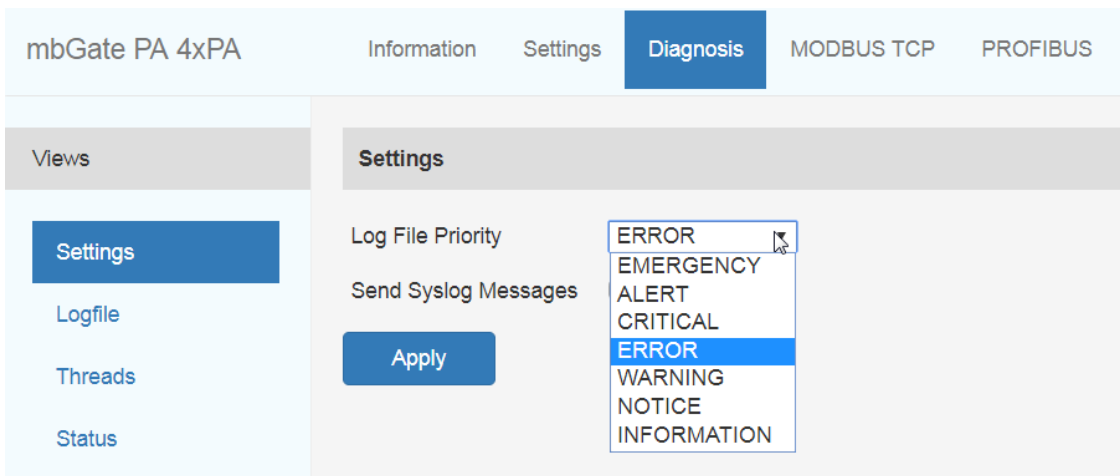

Parameter	Meaning
Log File Priority	Available values: Emergency, Alert, Critical, Error, Warning, Notice, Information. All messages with the set priority or higher are logged. The log file is shown under Diagnosis - Logfile
Send Syslog Messages	Activate additional debug logging and sends the information to the network. Can be logged with wireshark, Visual Syslog Server or similar.

8.4.2 Logfile

Select **Diagnosis** → **Logfile** to view the log file entries. You can also filter the diagnostic log by ticking and unticking the checkboxes of the different priorities. This only affects the display of the log and not the setting of the log file priority under **Diagnosis** → **Settings**.

The screenshot shows the 'Log File' section of the web interface. At the top, there are filter checkboxes for severity levels: EMERGENCY, ALERT, CRITICAL, ERROR, WARNING, NOTICE, INFORMATION, and DEBUG. Below these is a table with three columns: Severity, Timestamp (UTC), and Message. The table contains several entries, all with a severity of 'CRITICAL' and a message starting with '<PB-STACK> no fbc interrupt for request'. At the bottom right of the table area, there are three buttons: 'Clear', 'Refresh', and 'Support Data'.



Note

Use the button **[Support Data]** to save the data to a file. The information contained in this file may provide us with valuable information to fix your issue.

Parameter	Meaning
Emergency, Alert, Critical, Error, Warning, Notice, Information.	Tick checkboxes to set a filter.
Clear	Click this button to delete the log file entries.
Refresh	Click this button to update the message log entries.
Support Data	Click this button to upload a collection of all available logs for support requests.

8.4.3 Threads

Select **Diagnosis** → **Threads** to view currently running threads. The list you will see and the details contained may not be of any use to you but helps Softing support to diagnose device and performance errors.

Id	Name	State	Set Priority	Current Priority	Stack Base	Stack Size	Stack Used
1	Idle Thread	RUNNABLE	31	31	0x013498D0	8192	240
2	Clock mgmt	SLEEP	2	2	0x017828D0	12032	412
3	main	SLEEP	10	10	0x0134BF88	12000	1296
4	Network alarm support	SLEEP	27	27	0x0175A57C	8192	840
5	Network support	RUNNABLE	28	28	0x0162DA7C	8192	1240
6	jifs2_gc thread	SLEEP	30	30	0x0178E0C8	2048	752
7	FG-2xx jifs task	SLEEP	30	30	0x00A69748	16384	1248
8	SysLog	SLEEP	30	30	0x01776AE8	4096	428
9	FG-2xx ecc task	SLEEP	30	30	0x00A7DD1C	4096	196
10	FG-2xx firmware task	SLEEP	27	27	0x00A672A8	4096	240
11	FG-2xx capture task	SLEEP	27	27	0x00A87858	4096	276
12	FG-2xx console serial task	SLEEP	25	25	0x00A842C0	8192	1036

8.4.4 Status

Select **Diagnosis** → **Status** to view gateway diagnostics.

Status	
Uptime	15268
CPU Load (0.1s)	3
CPU Load (1s)	2
CPU Load (10s)	2
RAM size	99614720
RAM static	23623720
RAM dynamic used	356936
RAM dynamic free	75634044
Current Temperatur	42

8.5 MODBUS TCP

8.5.1 Settings

To change the Modbus TCP Settings you need to be logged in as [administrator](#)⁵⁰.

Select **MODBUS TCP** → **Settings** and follow the instructions in the section [Configuring Modbus](#)²⁵.

Parameter	Meaning
Obtain IP settings from a DHCP server	If the checkbox is selected, the IP settings for MODBUS TCP access are obtained from DHCP server. IP Address, Subnet Mask and Default Gateway cannot be configured.
IP Address	IP address for MODBUS TCP access.
Subnet Mask	Subnet mask
Default Gateway	Default gateway
Default TCP Port	Default TCP port
Additional TCP Port	If defined, this port can also be used for Modbus communication.
Watchdog [msec]	See Section Connection Monitoring ³⁵ .
Apply	Click button to activate your settings.

8.5.2 Mapping

The MODBUS TCP mapping table displays the mapping of PROFIBUS IOs to MODBUS.

The screenshot shows the 'Modbus Mapping' configuration page in the mbGate PB interface. The left sidebar contains 'Settings', 'Mapping' (selected), and 'Log'. The main area has tabs for 'Segment PA0', 'Segment PA1', and 'Segment DP0'. Under 'Segment PA0', there is a section for 'FBK Starter Kit' with 'Address: 10' and 'Device Type: FBK Starter Kit'. Below this, a table lists the module mappings:

Status Register:		8510		
Modules:				
Name	Slot	Input Registers	Output Registers	
OUT (long)	1	0 H - 2 H		No output data
OUT (long)	2	2 L - 4 L		No output data
SP (long)	3	No input data		0 H - 2 H
SP (long)	4	No input data		2 L - 4 L
OUT_D	5	5 H - 5 L		No output data
SP_D+RB_D	6	6 H - 6 L		5 H - 5 L

8.5.3 Log

The MODBUS TCP log represents the state of the Modbus connection. The data helps Softing Support to troubleshoot a connection problem.

8.6 PROFIBUS

8.6.1 Configuration

This section describes how to configure the gateway segments PA and DP for PROFIBUS communication. You need to be logged in as [administrator or configurator](#)⁵⁰ to configure the gateway.



Note

As all three gateways have the same PROFIBUS master interface, the configuration instructions for mbGate PA also apply to mbGate PB and mbGate DP.

Actions	Meaning
Import GSD	Import GSD device description file to device catalog.
Remove all GSDs	Deletes all previously imported GSDs.
Clear Configuration	Deletes all configured devices.
Load Configuration	Loads a previously saved configuration.
Save Configuration	Saves the configuration to a file.
Create Report	Creates a configuration report.
Export Unity Pro FBs	Creates an export file to be used with Unity Pro.
Apply Configuration	Saves the configuration to the device.



Note

You can adapt the baud rate and retry limits to network characteristics. The default baud rate is set to 1.5 Mbaut and the retry limit to 1.

Terms / Abbreviations	Meaning
Baudrate	The rate at which data is transferred in a PROFIBUS communication segment. "1.5MBaud" means that segment can transfer a maximum of 1.5 megabits per second.
Tsl	Slot Time: This time determines the maximum time the sender waits for a response from the addressed device.
Min TsdR	Minimum Station Delay Responder: The time that the slave must wait before it may respond to a request from the master. The default value is $11t_{Bit}$.
Max TsdR	Maximum Station Delay Responder: The time in which the slave must respond to a request from the master. The value range is set between 60 and $800 t_{Bit}$.
Ttr	Target Rotation Time: This time is the maximum time available for one Token rotation. In this time span, all DP masters receive the Token once.
Highest Station Address	Indicates the highest valid device address in the PROFIBUS network.
Tset	Setup Time: This is the time that may pass between receiving a data telegram and the respective reaction within a device.
Max Retry limit	The total number of retries.

8.6.2 Log

The PROFIBUS log represents the state of the PROFIBUS connection. The data helps Softing Support to troubleshoot a connection problem.

9 Declaration of conformity

This device is compliant with EC directive 2014/30/EG, "Electromagnetic Compatibility" (EMC directive) and meets the following requirements:

- EN 55011 Industrial, scientific and medical (ISM) devices - radio disturbance - limits and methods of measurement
- EN 55032 Electromagnetic compatibility of multimedia equipment (MME) and interference emission
- EN 61000-6-4 Electromagnetic compatibility (EMC); Part 6-4: generic standard – emission for industrial environments
- EN 61000-6-2 Electromagnetic compatibility (EMC); Part 6-2: generic standard - immunity for industrial environments



Note

To fulfill the EMC requirements, the other components of your installation (DC adapter, Industrial Ethernet devices, etc.) also have to meet the EMC requirements. A shielded cable must be used. In addition, the cable shield must be grounded properly.



CAUTION

This is a Class A product. In a domestic environment this product may cause radio interference in which case the user may be required to take adequate measures!



CE

The CE marking indicates conformity with the above standards in a Declaration of Conformity which can be requested from Softing Industrial Automation GmbH.



RoHS

This product is compliant the Restriction of Hazardous Substances under Directive 2002/95/EC.



FCC

This equipment has been tested and found to comply with the limits for a Class A digital device, under part 15 of the FCC Rules. These limits are designed to provide reasonable protection against harmful interference when the equipment is operated in a commercial environment. This equipment generates, uses, and can radiate radio frequency energy and, if not installed and used in accordance with the instruction manual, may cause harmful interference to radio communications.



VCCI

This Class A product conforms to the regulations of Voluntary Control Council for Interference (VCCI) by Information Technology Equipment.





WEEE

In compliance with Waste Electrical & Electronic Equipment (WEEE) Directive 2002/96/EC, electrical and electronic equipment must be disposed of separately from normal waste at the end of its operational lifetime. Packaging material and worn components shall be disposed of according to the regulations applicable in the country of installation.

This page is intentionally left blank.

Softing Industrial Automation GmbH

Richard-Reitzner-Allee 6
85540 Haar / Germany
<http://industrial.softing.com>

 + 49 89 45 656-340
 + 49 89 45 656-488
 info.idn@softing.com

